

VIBXPERT II Catalog

2 0 2 0



© PRÜFTECHNIK; All rights reserved

Printed in Germany

LIT 53.700.EN

VIBXPRT is a registered trademark of PRÜFTECHNIK AG.

CONTENTS

VIBXPERT II – Dual channel FFT data collector	5
Wheeled case for VIBXPERT II	16
USB cables for VIBXPERT II	17
Rechargeable battery for VIBXPERT II	18
Charger for VIBXPERT II	19
Carrying pouch with accessories for VIBXPERT II	20
Mobile industrial CLD accelerometer	21
Mounting adapters for vibration sensors	24
Pre-assembled sensor cables and adapters for CLD accelerometers (portable devices)	29
Extension cable for analog measuring channel, portable devices	30
Laser trigger / RPM sensor	31
Stand and accessories for laser trigger / RPM sensor	33
Pre-assembled sensor cable and adapter for trigger / RPM sensor (portable devices)	35
Charging station for VIBXPERT II rechargeable battery	40
OMNITREND Center	41
OMNITREND PC Software	42
VIBXPERT utility	44
VIBCODE vibration transducer	45
VIBCODE measurement studs	47
Accessories for VIBCODE measurement studs	50
Triaxial accelerometer	51
Displacement sensor for VIBXPERT II	53
Temperature probes	55
IEPE-type accelerometers	56
Ethernet cable for VIBXPERT II	59
Cable adapter for VIBXPERT II	60
Connection cable for field multiplexer on VIBXPERT II	62
Serial PC cables - RS232	63
Cables for signal output – handheld devices	65
Pre-assembled sensor cables for measuring low signal voltage/low signal current, portable measuring devices	66
Mono headphones	69

LED stroboscope70

Current clamp (400 A AC / 600 A DC)72

Tools for cable installation74

Tools for installation of accelerometers75

VIBXPert II – Dual channel FFT data collector

VIBXPert II is the expert system for performing vibration analysis, machinery diagnosis and balancing of rotors. This handy and versatile system is easy to operate, and its many functionalities and analysis tools make it unique.



Application

- Route-based data collection
- Automatic data acquisition with a multiplexer
- Vibration-based condition monitoring
- Field balancing (1 or 2 planes)
- Acceptance measurement with machine templates
- Troubleshooting
- Multimeter
- Data logging
- Visual inspection

Ordering information

Depending on application and functionalities, VIBXPert II is available in four variants.

Item No.	Variant
VIB 5.310-1E	VIBXPert II data collector, 1 channel
VIB 5.310-1	VIBXPert II data collector and signal analyser, 1 channel
VIB 5.310-2	VIBXPert II data collector and signal analyser, 2 channels
VIB 5.310 B	VIBXPert II Balancer, 2 channels

The items delivered within the box are shown in the following overview.

Scope of supply

Item No.	Content Description	Details	Data	Signal		Balancer
			VIB 5.310-1E	VIB 5.310-1	VIB 5.310-2	VIB 5.310 B
VIB 5.310	VIBXPert II instrument	p. 9	✓	✓	✓	✓
VIB 5.318-E	Firmware "E-Registration" incl. certificate	p. 10	✓	✗	✗	✗
VIB 5.311	Firmware "1 channel" incl. certificate	p. 10	✗	✓	✓	✗
VIB 5.311-CH2	Firmware "2 channels" incl. certificate	p. 10	✗	✗	✓	✗
VIB 5.317-B	Firmware "Balancer" incl. certificate	p. 13	✗	✗	✗	✓
VIB 5.325	Battery (built-in)	p. 18	✓	✓	✓	✓
VIB 5.327	Wheeled case	p. 16	✓	✓	✓	✓
VIB 5.356	Carrying pouch	p. 20	✓	✓	✓	✓
VIB 5.320-INT	Charger, International	p. 19	✓	✓	✓	✓

Item No.	Content Description	Details	Data	Signal		Balancer
			VIB 5.310-1E	VIB 5.310-1	VIB 5.310-2	VIB 5.310 B
VIB 5.330SUSB	USB cabel	p. 17	✓	✓	✓	✓
VIB 5.350-USB	USB flash drive	p. 17	✗	✗	✗	✓
VIB 5.330AMEM	Connection cable for USB flash drive	p. 17	✗	✗	✗	✓
VIB 6.142 R	Mobile Industrial accel-erometer, 1 $\mu\text{A}/\text{ms}^{-2}$	p. 21	✓	✓	✓, 2x	✗
VIB 6.147	Mobile Industrial accel-erometer, 5,35 $\mu\text{A}/\text{ms}^{-2}$	p. 21	✗	✗	✗	✓, 2x
VIB 3.420	Magnetic holder for curved sur-faces	p. 24	✓	✓	✓, 2x	✓, 2x
VIB 5.436	Sensor cable for CLD-type accel-erometer, sprialized	p. 29	✓	✓	✓, 2x	✓
VIB 5.437-2,9	Sensor cable for CLD-type accel-erometer, straight, 2.9m/9.5ft	p. 29	✗	✗	✗	✓
VIB 5.339	Cable extension for analog measurement channel, 8 m	p. 29	✗	✗	✗	✓
VIB 6.631	Laser trigger / RPM sensor	p. 31	✗	✗	✗	✓
VIB 6.632	Stand for Laser trigger	p. 33	✗	✗	✗	✓
VIB 5.432-2,9	Sensor cable for laser trigger / RPM sensor, straight, 2.9 m / 9.5 ft	p. 35	✗	✗	✗	✓
VIB 4.750-5	Extension for Laser Trigger sensor cable, straight, 5 m / 16 ft	p. 35	✗	✗	✗	✓
VIB 3.306	Reflective tape, 10 mm wide	p. 33	✗	✗	✗	✓
LIT 53.102	Short instructions, VIBXPERT II	---	✓	✓	✓	✗
LIT 53.103	Short instructions, VIBXPERT II Balancer	---	✗	✗	✗	✓
LIT 01.801	Condition Monitoring Docu-mentation, USB flash drive	---	✓	✓	✓	✓
LIT 66.200	Manual, Laser trigger	---	✗	✗	✗	✓
LIT 01.101	Safety information, Vibration sensors	---	✓	✓	✓	✓
VIB 2.520.G	VIBXPERT inspection certificate	---	✓	✓	✓	✓

Note: The items in the box for the four variants are fixed. A customized configuration is possible.

Optional items may be ordered for any of the four variants:

Optional accessories

Item No.	Description – optional accessories	Note	Details
OMNITREND Center PC software			
VIB 8.200	OMNITREND Center Client Server		p. 41
VIB 8.201/ 8.202	Floating user licenses: 1 / 5		p. 41
VIB 8.203 / 8.204	Fix user licenses: 1 / 5		p. 41
VIB 8.205	10 additional database licenses		p. 41
VIB 8.210	OMNITREND Center single user		p. 41
VIBXPERT II Firmware Upgrade			
VIB 5.315-REC	Firmware "Recording"	incl. certificate and USB flash drive. Required: " VIBXPERT-Utility Advanced File Export (PC licence)" for data export (p. 44)	p. 12
VIB 5.316-BAL	Firmware "Balancing"	incl. certificate and USB flash drive.	p. 12
VIB 5.319-ODS	Firmware "ODS - Modal analysis"	incl. certificate and USB flash drive. Only with firmware "2 channels". Required: " VIBXPERT-Utility Advanced File Export (PC licence)" for data export.	p. 12
VIB 5.384-FM	Firmware "Machine Templates"	incl. certificate and USB flash drive.	---
OMNITREND PC software			
VIB 8.981	OMNITREND for VIBXPERT		p. 42
VIB 8.982	OMNITREND View for VIBXPERT		p. 42
VIB 8.982-B	OMNITREND View Basic for VIBXPERT		p. 42
VIB 8.981-OMT	VIBXPERT device driver for OMNITREND	= device type licence	p. 42
VIB 5.312-P	PC licence for VIBXPERT II	= communication licence	p. 42
VIB 8.970	OMNITREND Demo CD		---
VIBXPERT utility PC software			
VIB 8.984	VIBXPERT-Utility Advanced File Export	PC licence	p. 44
VIB 8.986	VIBXPERT-Utility Excel Report module	PC licence	p. 44
Sensors			
VIB 8.660	VIBCODE sensor	w/o connection cable	p. 45
VIB 6.655	Triaxial accelerometer for mobile applications	required: Connection adapter	p. 51
VIB 6.640	Inductive proximity probe	incl. cable	p. 53
VIB 8.607-1,5	Temperature probe with magnetic attachment	incl. connection cable (1.5 m)	p. 55
VIB 8.608	Handheld temperature probe	incl. connection cable	p. 55
VIB 6.172	Accelerometer 100mV/g (IEPE-type) with MIL-type connector		p. 56
Cables and connection adapters			
VIB 5.331	Ethernet cable		p. 59

Item No.	Description – optional accessories	Note	Details
VIB 5.332-X	Keyphase adapter for machine protection systems	Required: Sensor cable for laser trigger / RPM sensor	p. 35
VIB 5.333	Connection adapter for LED strobe light	Required: Sensor cable for laser trigger / RPM sensor	p. 35
VIB 5.336	Sensor cable for triaxial accelerometer VIB 6.655		p. 60
VIB 5.345-6	Extension for sensor cable with MIL connector, 6 m, MIL plug to MIL socket		p. 60
VIB 5.346	Connection cable for VIBRONET field multiplexer		p. 62
VIB 5.346-MUX	Cable adapter for the connection cable VIB 5.346		p. 62
VIB 5.422	Sensor cable for accelerometer (IEPE), spiral, 1.8 m, MIL connector to MiniSnap		p. 60
VIB 5.430-2	Serial PC cable		p. 63
VIB 5.431	Connection cable for external analyzers to analogOUT		p. 65
VIB 5.433	Sensor cable for measuring low voltage signals		p. 66
VIB 5.434	Sensor cable for measuring low current signals		p. 66
VIB 5.437-5	Sensor cable for CLD-type accelerometer, straight, 5 m / 16 ft		p. 29
VIB 5.438-0.5	Sensor cable for IEPE-type accelerometer		p. 60
VIB 5.443	Sensor cable for TTL trigger (foreign manufacturer)		p. 35
VIB 5.444-5	Cable extension for analog channel, 5 m / 16 ft		p. 30
VIB 5.449-CLD	Connection adapter for CLD-type accelerometer (VIB 6.195)		p. 29
VIB 6.675	Connection cable for Mono headphones		p. 65
Miscellany			
VIB 3.450	Probe tip for Mobile Industrial accelerometer VIB 6.14x		p. 24
VIB 5.324	Charging station		p. 40
VIB 5.354-GT	Carrying strap		p. 20
VIB 5.354-HS	Hand strap for VIBXPERT pouch		p. 20
VIB 5.354-CL	Sensor clip for VIBXPERT pouch		p. 20
VIB 6.671	Mono headphones, jack 3.5 m	Required: Connection cable for Mono headphones	p. 69
VIB 6.672	LED-Stroboscope	Required: Connection adapter for LED strobe light and sensor cable for laser trigger	p. 70
VIB 6.673	Current clamp 600A DC	Required: Sensor cable for measuring low voltage signals	p. 72

TECHNICAL INFORMATION

Technical data

Parameter	Technical data VIBXPERT II instrument (VIB 5.310)
INPUT	
Analog, Vibration, 2x	Voltage (AC/DC, ± 30 V max.) Current (AC/DC, ± 30 mA max.) IEPE-type accelerometer (2 mA, 24 V max.) Current Linedrive (CLD) accelerometer (10 V, 10 mA max.)
Frequency range	DC ... 51.2 kHz (Acceleration from 0.5 Hz)
Dynamic range	96 dB (measurement) / 136 dB (total)
Sampling frequency	up to 131 kHz per channel
Impedance	90 kOhm, with cable VIB 5.433
Analog, Temperature, 1x	Thermocouple (type K)
Digital, Pulse/ Tacho, 1x	RPM, Trigger, Keyphaser with pulse and AC signals: 0 V ... +26 V or -26 V ... 0 V
Max. input voltage	± 26 V
Switching threshold for 0 V ...+26 V signal	max. 2.5 V rising, min. 0.6 V falling
Switching threshold for -26 V ...0 V signal	min. -8 V rising, max. -10 V falling
Pulse width	< 0.1 ms
OUTPUT	
Stroboscope control	TTL
Frequency range	0 - 500 Hz
Resolution	0.05 Hz
Signal-Out	Connection for headphones to listen to the analog input signal; signal processing (oscilloscope)
Frequency range	0.5 Hz - 40 kHz
Output impedance	100 Ohm
MEASUREMENT RANGE / ACCURACY	
Vibration acceleration	depends on the sensor connected
Shock pulse	-10 ...80 dBsv / ± 3 dBsv
RPM	10 ... 200 000 min ⁻¹ / $\pm 0.1\%$ or ± 1 min ⁻¹ (the lower accuracy is applicable)
Temperature, type K	-50 ... +1000°C / 1% or ± 1 °C (the lower accuracy is applicable)
Standards fulfilled	Frequency response acc to ISO 2954
DISPLAY	
Type	TFT-LCD, backlit
Pixel area	116 x 87 mm
Resolution	VGA (640 x 480 pixel) with 140 ppi

Parameter	Technical data VIBXPRT II instrument (VIB 5.310)
Color depth	18 bit (262144 colors)
POWER SUPPLY	
Battery type	Li Ion rechargeable battery pack (7.3V / 5.3Ah - 38.7 Wh)
Charging time	< 5 hours in the instrument
Charger, input	110-240 V / 50-60 Hz
Charging temperature	0°C ... +50°C [32 °F ... 122°F]
COMPUTER	
Processor	Marvell PXA320 806 MHz
Keyboard	1 navigation pad and 7 keys (Zoom, Escape, Function, Help, Menu, On/Off); Keyboard illumination controlled by ambient light.
Memory	Internal: 128 MB DDR RAM; Compact Flash: 2 GB to 8 GB (interchangeable)
Serial interface	RS 232, <115 kBaud
USB interface	USB 2.0
Ethernet interface	100 Mbit (100Base T), 10 Mbit (10Base T)
ENVIRONMENT / GENERAL	
Connectors	Analog / Digital channels: MiniSnap socket Thermocouple (type K): QLA socket; all compatible to VIBSCANNER
Housing	ABS plastics
Dimensions	186 x 162 x 52 mm (LxWxH), [7 5/16" x 6 3/8" x 2 1/16"]
Weight	approx. 1.1 kg [39 oz]
Environmental protection	IP65, dust and splash-proofed
Temperature range	-10°C ... +60°C (Operation), [14 °F ... 140°F] -20°C ... +60°C (Storage), [-4 °F ... 140°F]

Standard firmware features

Parameter	1 channel/ 2 channels (VIB 5.311 / VIB 5.311-CH2)	'E-Registration' (VIB 5.318-E)
OPERATING MODES		
Machine templates	Machine-specific templates for repetitive measurement tasks used for acceptance tests or service measurements.	---
Route	<ul style="list-style-type: none"> • Set of measurement tasks for machine condition monitoring and diagnosis • Route guidance via tree / list view or machine graphics • Optimizer levels, TrendingSpectrum, 'Near location' mode for rapid data collection 	
Multimode, Characteristic Overall Values	<ul style="list-style-type: none"> • Overall Vibration (Acceleration, Velocity, Displacement) • Current, Voltage (AC / DC) • Shock pulse (bearing condition) • Temperature • Rotational speed 	

Parameter	1 channel/ 2 channels (VIB 5.311 / VIB 5.311-CH2)	'E-Registration' (VIB 5.318-E)
Multimode, Signals	<ul style="list-style-type: none"> • Amplitude spectrum for acceleration, velocity, displacement, current, voltage • Envelope spectrum for acceleration, velocity • Time waveform for acceleration, velocity, displacement, current, voltage • Phase measurement (polar diagram) • Impact test w/o recording of the exciting force • Run-up/ Coast-down analysis for acceptance checks and for the evaluation of resonances; phase over RPM (Bode or Nyquist diagram); overall value over RPM (RMS and either 0-p, p-p or crest factor). <p>with 2-channel firmware only (VIB 5.311-CH2):</p> <ul style="list-style-type: none"> • 2-channel measurements with trigger • Orbit (filtered / unfiltered) • Cepstrum • Cross channel phase measurement • Impact test for natural frequency analysis on a shutdown or running machine* • ODS - Operation deflecting shape analysis* <p>* requires optional firmware module VIB 5.319-ODS</p>	<ul style="list-style-type: none"> • Amplitude spectrum for acceleration, velocity, displacement, current, voltage • Envelope spectrum for acceleration, velocity • Time waveform for acceleration, velocity, displacement, current, voltage
ANALYSIS FUNCTIONS		
Cursor	single, delta, harmonics, sub harmonics, sideband cursor	
Frequency markers	Fixed and RPM-variable characteristic frequencies for machines, roller bearings and gearboxes can be displayed in 'Template' and 'Route' mode	
Alarm bands	Narrow band monitoring of damage frequencies (route mode only)	
Max 10 values	List of the 10 highest amplitudes in the spectrum	
Results display	<ul style="list-style-type: none"> • Linear scaling, Logarithmic scaling (Y axis) • Trend, Cascade diagram (waterfall), Polar plot • Order scaling for amplitude / envelope spectrum • Sound spectrum (octave / third octave bars) 	
MEASUREMENT FUNCTIONS		
Multi Meas. tasks	Combination of several measurements in one task.	
Averaging	<ul style="list-style-type: none"> • none (not for temperature), • linear (not for time waveform), • peak hold (not for time waveform and temperature), • exponential (not for time waveform & temperature), • time-synchronous (time waveform, spectrum, balancing) 	

Parameter	1 channel/ 2 channels (VIB 5.311 / VIB 5.311-CH2)	'E-Registration' (VIB 5.318-E)
Trigger modes	<ul style="list-style-type: none"> • Free running, external (time-synchronous), internal • Amplitude, Edge, Pre and post triggered. 	
FFT	<ul style="list-style-type: none"> • Fmin: between 0.5 Hz and 10 Hz programmable • Fmax: between 200 Hz and 51.2 kHz programmable • Lines: 400, 800, 1600, 3200, 6400, 12800, 25600, 51200, 102400 • Window: Rectangular, Hanning, Hamming, Blackman, Bartlett, Flattop, Kaiser 	

Optional firmware features

Parameter	Optional firmware modules
RECORDING - VIB 5.315-REC	
Short-term recording	<ul style="list-style-type: none"> • Characteristic overall values, phase, spectrum and time waveform • Pre- and post history
Start / stop triggering	time, rpm, threshold, manual
Recording duration	approx. 10 minutes for time waveform with 512 Hz sampling rate
Time waveform recorder	Continuous long-term signal recording.
Recording duration	approx. 132 hours with 512 Hz sampling rate and 2 GB CF card
Requirements	Use of the time waveform recorder requires registration of either the "E-Registration" firmware (VIB 5.318-E) or the 1-channel firmware (VIB 5.311). The software module "VIBXPRT utility - Advanced file export - VIB 8.984" is required for data export.
BALANCING - VIB 5.316-BAL	
Meas. quantities	Vibration velocity, acceleration, displacement
Balancing modes	One-plane balancing with vibration minimization in the second plane Balancing in two planes under operating conditions
RPM range	30 to 199.000 min ⁻¹
Correction type	Fixed location, Fixed mass, Tape measure, Free correction
Operation	Graphical user interface with machine icons and on-screen instructions
Additional measurement tasks	Diagnosis measurements for detecting an imbalance (characteristic overall value, spectrum, time waveform, phase)
Add. averaging type	Unlimited averaging if the imbalance pointer is unstable
ODS / MODALANALYSIS - VIB 5.319-ODS	
Bump test with modal hammer	Analysis of operation-critical mode shapes, Visualization of the dynamic behavior of a structure
Results display	Transmission function, Coherence function
Add. averaging type	Negative averaging for measurements on a running machine
ODS	Structure analysis on running machine
Requirements	Standard firmware "1-channel" and "2 channels " must be registered; The software module "VIBXPRT utility - Advanced file export - VIB 8.984" is required for data export.

Balancer firmware features

Parameter	Balancer firmware (VIB 5.317-B)
OPERATING MODES	
Multimode, Characteristic Overall Values	<ul style="list-style-type: none"> • Vibration (Acceleration, Velocity, Displacement) • Temperature • Overall value for user-defined quantity (AC)
Multimode, Signals	<ul style="list-style-type: none"> • Amplitude spectrum w/ fixed parameters for accel., velocity, displacement • Run-up/ Coast-down analysis for acceptance checks and for the evaluation of resonances; phase over RPM (Bode or Nyquist diagram); overall value over RPM (RMS and either 0-p, p-p or crest factor) • Vibration pointer (phase - speed) with recording function for the evaluation and documentation of the time response, the speed dependency of vibrations and for the quick evaluation of the phase reference of measurement points. • Time waveform for acceleration, velocity, displacement • Time waveform for user-defined quantity (AC) • Phase measurement w/ recording • Impact test w/o recording of the exciting force, 1 channel • Amplitude spectrum w/ fixed parameters for user-defined quantity (AC) • Envelope spectrum of acceleration (fmax.: 800 Hz / HP: 10kHz) for bearing analysis and analysis of shock-excited vibrations.
Balancing	<ul style="list-style-type: none"> • One-plane balancing; optional: vibration minimization in the second plane • Balancing in two planes under operating conditions • Correction type: Fixed location, Fixed mass, Tape measure, Free correction • Calculation of balancing grade and residual centrifugal force • Balancing speed: 30-199,000 1/min • Balancing report with selectable options
ANALYSIS FUNCTIONS	
Cursor	single, delta, harmonics, sub harmonics, sideband cursor
Max 10 values	List of the 10 highest amplitudes in the spectrum
Results display	<ul style="list-style-type: none"> • Linear scaling, Logarithmic scaling (Y axis) • Trend, Cascade diagram (waterfall), Polar plot • Order scaling for amplitude / envelope spectrum
MEASUREMENT FUNCTIONS	
Averaging	<ul style="list-style-type: none"> • none (not for temperature), • linear (not for time waveform), • peak hold (not for time waveform and temperature), • exponential (not for time waveform & temperature), • time-synchronous (time waveform, spectrum, balancing) • Unlimited averaging if the imbalance pointer is unstable
Trigger modes	<ul style="list-style-type: none"> • Free running, external (time-synchronous), internal • Amplitude, Edge, Pre and post triggered.
FFT	<ul style="list-style-type: none"> • Fmin: 1 / 2 / 10 Hz, selectable acc. to meas. quantity • Fmax: 0,2 / 0,4 / 0,8 / 1,6 / 12,8 kHz, selectable acc. to meas. quantity • Lines: 800 / 1600 / 3200 / 6400, selectable acc. to meas. quantity • Window: Hanning

empty page

Components

The following section provides detailed information about the components and the optional accessories.

Note: Some components are not suitable for use with VIBXPART II for technical reasons.

Wheeled case for VIBXPART II	16
USB cables for VIBXPART II	17
Rechargeable battery for VIBXPART II	18
Charger for VIBXPART II	19
Carrying pouch with accessories for VIBXPART II	20
Mobile industrial CLD accelerometer	21
Mounting adapters for vibration sensors	24
Pre-assembled sensor cables and adapters for CLD accelerometers (portable devices)	29
Extension cable for analog measuring channel, portable devices	30
Laser trigger / RPM sensor	31
Stand and accessories for laser trigger / RPM sensor	33
Pre-assembled sensor cable and adapter for trigger / RPM sensor (portable devices)	35

Wheeled case for VIBXPERT II

This robust wheeled case is intended for storage and transportation of the measuring equipment. The unbreakable hard shells and shock absorbing insert foam ensure safe protection of the components.



Wheeled case for VIBXPERT II.

Features

- Lightweight strong HPX® resin
- Watertight
- Meets Carry-on regulations
- Vortex® valve
- Padlockable hasp
- Lifetime guarantee
- In-line wheels
- Telescopic pull-out handle
- Weight (empty): 5.8 kg (12.8 lb)
- Dimensions: 551 x 358 x 226 mm [21 11/16" x 14 1/8" x 8 7/8"]

Ordering information

Item No.	Description
VIB 5.327	Wheeled case for VIBXPERT II

USB cables for VIBXPert II

This cable is designed for data transfer between VIBXPert II and a PC. A USB flash drive and a matching connection cable are available for storing measured data on an external data storage medium.





USB cable for data transfer connected to VIBXPert II.

Features

- USB 2.0
- Storage medium with 4 GB

Ordering information

Item No.		Description
VIB 5.330 SUSB		USB cable for VIBXPert II, 2.9 meters, USB to MiniSnap
VIB 5.330AMEM		Connection cable for USB flash drive
VIB 5.350-USB		USB flash drive, 4 GB

Note: These cables and adapters must not be operated with VIBXPert EX.

Rechargeable battery for VIBXPERT II

The powerful rechargeable Li-ion battery supplies VIBXPERT II on your daily measurement route. Intelligent power saving functions in the measuring device preserve rechargeable battery reserves and ensure long operating times. The rechargeable battery can be charged in the measuring device or in the charging station available as accessory item.



Lithium-ion rechargeable battery for VIBXPERT II.

Features

- Operating time typically 8 hours
- Lithium ion cells
- Charge time < 5 hours

Ordering information

Item No.	Description
VIB 5.325	VIBXPERT II rechargeable battery

TECHNICAL INFORMATION

Technical data

Parameter	VIBXPERT II rechargeable battery - VIB 5.325
Type	Li ion rechargeable battery
Rated voltage	7.3 V
Rated capacitance	5.3 Ah
Rated output	38.7 Wh
Charge temperature range	0 °C ... + 50 °C [32 ... 122 °F]
Charge time	< 5 hours

Charger for VIBXPERT II

Using this charger, the measuring device can be operated with mains power (e.g., in the office) or the rechargeable battery for VIBXPERT-II can be charged, either in the measuring device or in the charging station available as accessory item.



Features

- Protection class II
- Output: 12 V / 3 A
- Five international plug adapters:
 - North America, Japan
 - Australia
 - UK
 - EU
 - China

Charger for VIBXPERT II including plug adapter.

Ordering information

Item No.	Description
VIB 5.320-INT	Charger for VIBXPERT II, international

TECHNICAL INFORMATION

Technical data

Parameter	Charger for VIBXPERT II - VIB 5.320-INT
Input	100 - 240 VAC / 50 - 60 Hz / 1.0 A
Output	12 VDC / 3.0 A / 36 W
Connection on measuring device	Analog channel A or B
Protection class	II / IP 52

Carrying pouch with accessories for VIBXPert II

The robust carrying pouch features a side pocket for sensors, cables, and tools. The carrying strap and hand strap can be adjusted continuously via Velcro fastener.



Features

- Nylon blended fabric
- Velcro fastener
- Sturdy
- Washable

Carrying pouch (A) with shoulder strap (B) and hand strap (C).

Ordering information

Item No.	Description
VIB 5.356	VIBXPert II carrying pouch
VIB 5.354-GT	VIBXPert II shoulder strap
VIB 5.354-HS	VIBXPert II hand strap
VIB 5.354-CL	Sensor clip for VIBXPert pouch

Application example

Sensor clip for VIBXPert pouch

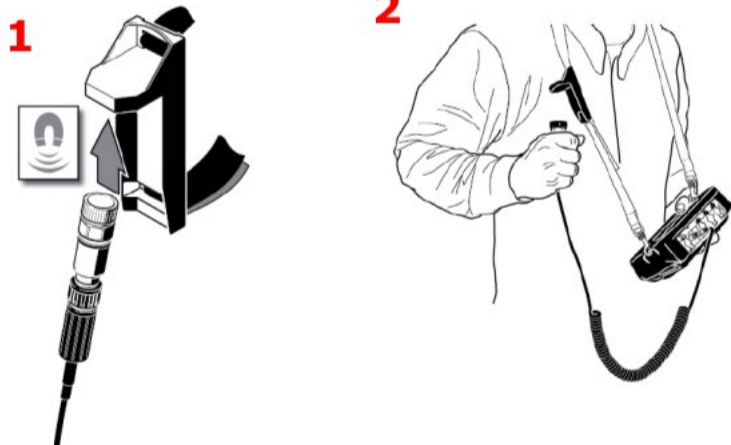

1: Sensor connects magnetically to the sensor clip.

2: Sensor clip is a practical sensor holder between the measurements.

Mobile industrial CLD accelerometer

This sensor is intended for vibration measurement on machinery within industrial environments using a portable data collector. Optional magnetic adapters for mounting at the measurement points are available.



Features

- 3-in-1 sensor: housing vibration, shock pulse (condition of roller bearings), cavitation
- Intrinsic safety, Zone 0, 1, 20
- f_{\min} : 0.3 Hz – ideal for machines running at low speeds
- Rigid mounting using threaded screws
- Current Line Drive (CLD) output for long cable use
- Immune to interference (Tandem-Piezo)

Industrial accelerometer for mobile data collection

Ordering information

Item No.	Industrial accelerometer for mobile data collection
VIB 6.142 R	Standard, mobile
VIB 6.147	Low speed, mobile

Accessories

Item No.	Description / Group
Miscellaneous	"Mounting adapters for vibration sensors", p. 24

TECHNICAL INFORMATION

Technical data - VIB 6.14x (mobile)

Parameter	VIB 6.142	VIB 6.147
MEASUREMENT		
Signaling system	Current Line Drive, 3.5 mA static current with superimposed AC signal	
Transmission factor	1,0 $\mu\text{A}/\text{ms}^{-2} \pm 3\%$ (Ref.: 159 Hz; 25 °C)	5,35 $\mu\text{A}/\text{ms}^{-2} \pm 4\%$ (Ref.: 159 Hz; 25 °C)
Frequency range, $\pm 5\%$	2.5 Hz to 13 kHz	1 Hz to 3 kHz
Frequency range, $\pm 10\%$	1.6 Hz to 17 kHz	0.7 Hz to 8 kHz
Frequency range, $\pm 3\text{dB}$	1 Hz to 20 kHz	0.3 Hz to 10 kHz
Resonance frequency	36 kHz	17 kHz; > 20dB damped
Linearity range, $\pm 10\%$	$\pm 961 \text{ ms}^{-2}$	$\pm 450 \text{ ms}^{-2}$
Temperature range	-40 °C to 100 °C (-40 °F to 212 °F)	
ELECTRICAL		
Power supply	> 10 mA / 7-18 VDC	
Transverse sensitivity	< 5% at 10 kHz	
Temperature transient sensitivity	< 0.05 ms^{-2}/K	< 0.01 ms^{-2}/K
Magnetic field sensitivity	< 5 ms^{-2}/T (at 50 Hz)	< 1 ms^{-2}/T (at 50 Hz)
Base strain sensitivity	< 0.1 $\text{ms}^{-2}/\mu\text{m}/\text{m}$	
Electrical noise, rms	< 0.01 ms^{-2} from 2 Hz	< 0.002 ms^{-2} from 2 Hz
Output impedance	> 1 MOhm	> 300 kOhm
Insulation	> 10 ⁹ MOhm	
MECHANICAL		
Case material	Stainless steel VA 1.4305	
Environmental protection	IP 65 with cable connector locked	
Cable connection	TNC socket	
Mounting	Magnetic holder / M5 thread	
Shock limit	< 250 kms^{-2}	< 50 kms^{-2}
Weight	39 g	38 g

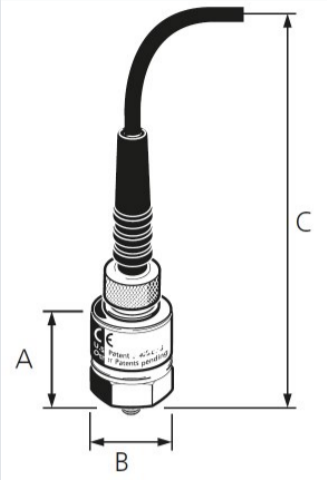
Parameter	VIB 6.142	VIB 6.147
Dimensions 	A = 40 mm / B = 21 mm / C = 120 mm (A = 1.6" / B = 0.8" / C = 4.7")	A = 45 mm / B = 21 mm / C = 125 mm (A = 1.8" / B = 0.8" / C = 4.9")

Frequency response

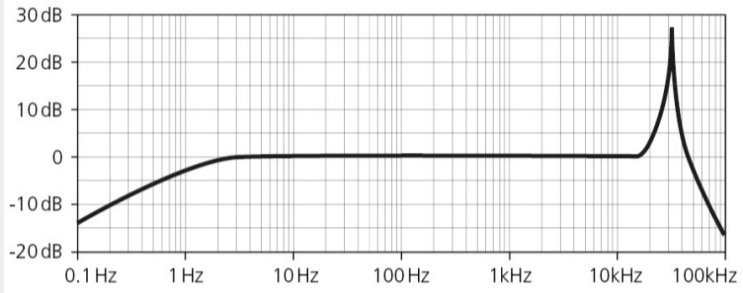
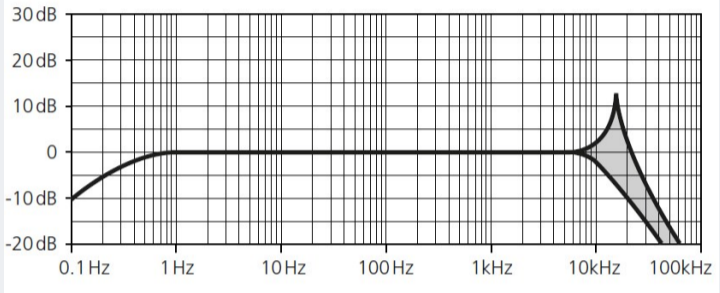
1 Hz - 20 kHz	0.3 Hz - 10 kHz
	
Type: <ul style="list-style-type: none"> VIB 6.142 R, VIB 6.142 DEX, VIB 6.142 EX0 (screwed or adhesive mounting)* * Linear frequency range limitation: <ul style="list-style-type: none"> - Magnetic adapter: < 5 to 20 kHz - Probe tip: < 1 kHz 	Type: <ul style="list-style-type: none"> VIB 6.147, VIB 6.147 DEX, VIB 6.147 EX0 (screwed or adhesive mounting)* * Linear frequency range limitation: <ul style="list-style-type: none"> - Magnetic adapter: < 5 kHz - Probe tip: < 1 kHz

Intrinsic safety details

	VIB 6.142 EX0 / VIB 6.147 EX0
ATEX	Marking: II 1G Ex ia IIC T4 Ga ; II 1D Ex ia IIIC T135°C Da
IECEX	Marking: II 1G Ex ia IIC T4 Ga ; II 1D Ex ia IIIC T135°C Da
CSA	Marking: Ex ia IIC T4 Ga ; Ex ia IIIC T135°C Da
Temperature range	-40 °C to 80 °C (-40 °F to 176 °F)

Mounting adapters for vibration sensors

Vibration sensors are mounted using adapters that conform to the structural shape of the sensor. In addition to these, different types of adapters are available. Depending on the application and the on-site requirements, sensors may be fixed to the machine by being screwed down or held secure using adhesives or magnets.



Mounting options for an "industrial" accelerometer

Fixation options

- Screwed mounting
- Glued mounting
- Magnetic connection
- Connection using a probe tip

Suitable for following types of sensors:

- "Industrial" CLD accelerometer
- "Mini" CLD accelerometer
- IEPE accelerometer "100 mV/g",
- "Wind" CLD accelerometer
- VIBROTECTOR vibrations monitor

Ordering information

Mounting adapters for industrial accelerometers VIB 6.122, VIB 6.125, VIB 6.127, VIB 6.129

Item No.	Description	Application / Hint
VIB 8.772	Screwed adapter to M10	For installation into an existing M10 hole, e.g. jack ring thread.
VIB 3.411 VIB 3.412 VIB 3.413	Screwed adapter with locking nut to M8 / M10 / M12	For measurement points located directly under a thin cover (e.g. guard plate, housing). The adapter may be used to replace existing casing screws.
VIB 3.431	Adhesive adapter, M8 to adhesive mount	For measurement points where mounting holes cannot be drilled. Fix using a two-component adhesive (e.g. WEICON HB 300). The adhesive adapter is also suitable for the "100mV/g (IEPE)" accelerometer type VIB 6.210.
VIB 8.586 / VIB 8.587 / VIB 8.588 / VIB 8.589	Extension post, Length: 55 / 95 / 170 ¹ / 35 mm (2.16" / 3.74" / 6.70" / 1.38")	For measurement points that are difficult to access or located inside a guard plate. Diameter: 12 mm (15/32")

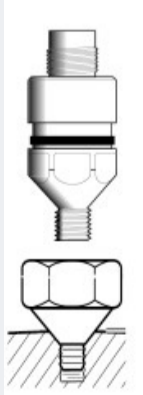
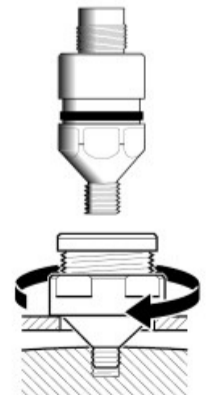
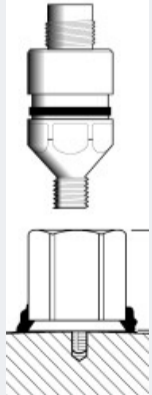
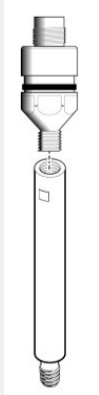
	VIB 8.772	VIB 3.411 ..13	VIB 3.431	VIB 8.586 ..89
Sensor + Adapter				

¹170 mm (6.70") for shock pulse measurements only

Mounting adapters for mobile industrial sensors, VIB 6.142, VIB 6.147

Item No.	Description	Application / Hint
VIB 3.420	Magnetic adapter for curved surfaces	For measurement locations made of ferromagnetic material. Shock pulse measurements (roller bearing condition) are not possible with these adapters.
VIB 3.422	Magnetic adapter for flat surfaces	
VIB 3.430	Adhesive adapter	For measurement points where mounting holes cannot be drilled. Fix using a two-component adhesive (e.g. WEICON HB 300).
VIB 3.435 / VIB 3.436 / VIB 3.440	Screw adapter on M5-120° / M6-90° / M8-90°	
VIB 3.450	Probe tip	Manual coupling to the measurement location. Material: Aluminium; Dimensions: 19 x 73 mm [3/4" x 2 7/8"] (D x H)

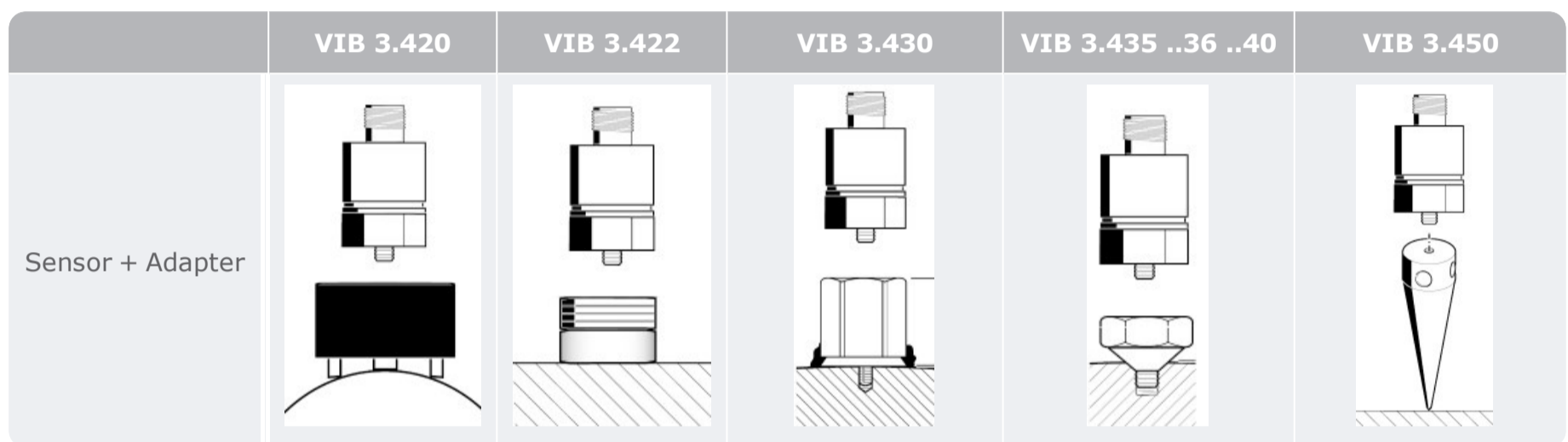

Mounting adapter for mini-sensor, VIB 6.202, VIB 6.203

Item No.	Description	Application / Hint
VIB 3.417-M5 / VIB 3.417-M6	Screw adapter on M5 / M6	
VIB 3.418	Adhesive adapter	For measurement points where mounting holes cannot be drilled. Fix using a two-component adhesive (e.g. WEICON HB 300).
VIB 3.423	Magnetic adapter	
VIB 3.480	M8 threaded pin	Installed in the sensor as standard. Can be replaced if necessary.

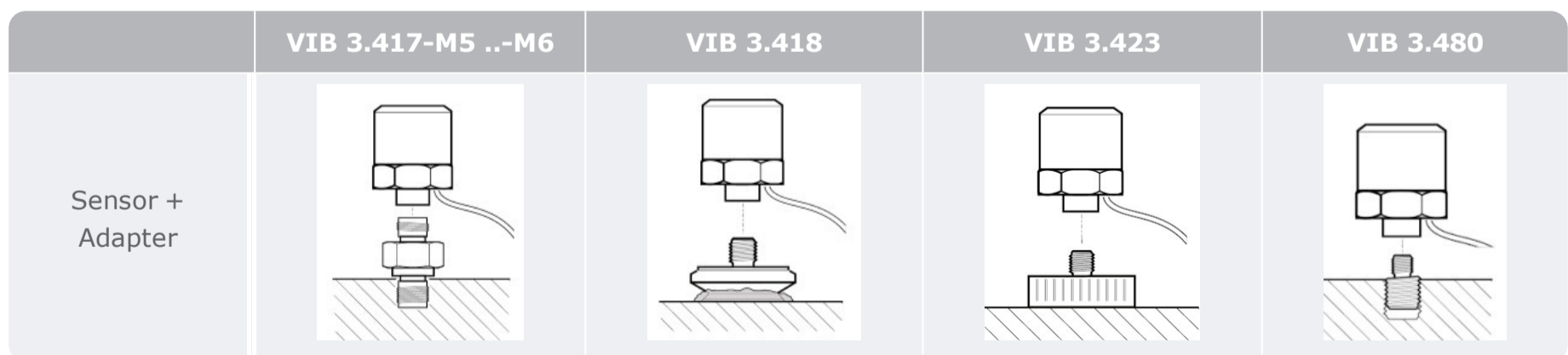

Mounting adapters for VIBROTECTOR and sensor types VIB 6.195, VIB 6.172 (Wind, IEPE-100mV/g)

Item No.	Description	Application / Hint
VIB 3.480	M8 threaded pin	Installed in the sensor as standard. Can be replaced if necessary.
VIB 3.437	Screw adapter on M8-90°	
VIB 3.438	Screw adapter on M8 flat	
VIB 3.439	Screw adapter on M5 flat	This adapter is used to mount the sensor on the magnetic adapter VIB 3.420.
VIB 3.433	Adhesive adapter	For measurement points where mounting holes cannot be drilled. Fix using a two-component adhesive (e.g. WEICON HB 300).
VIB 3.423	Magnetic adapter	

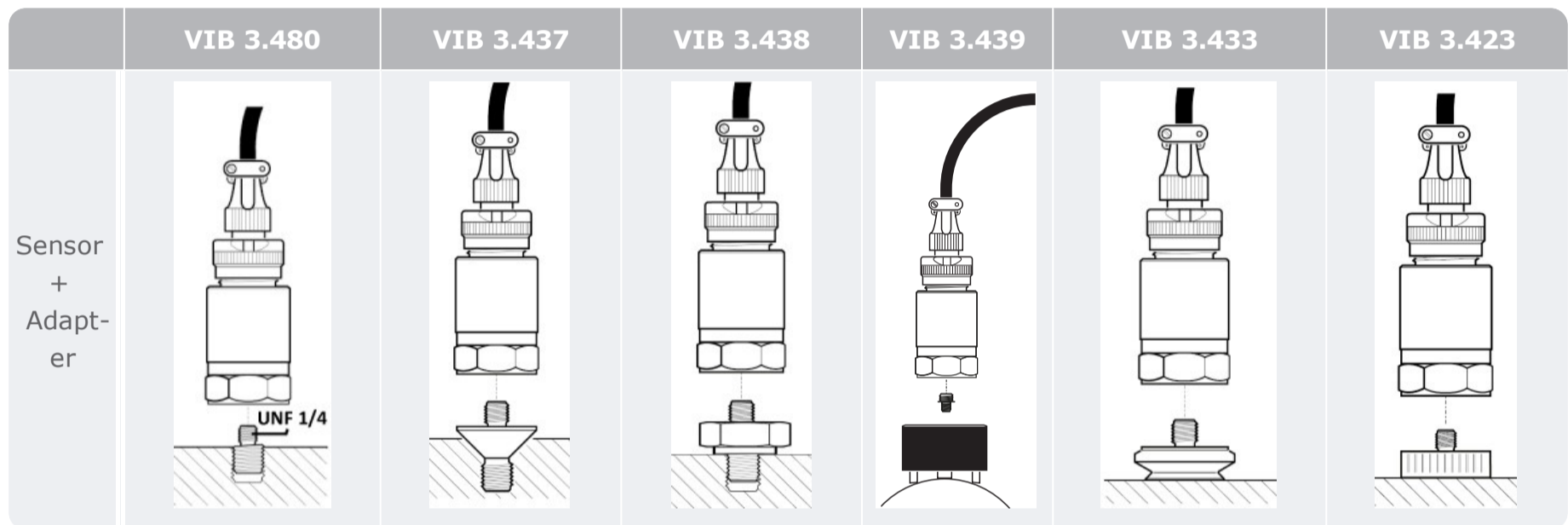

Mounting adapter for Triaxial sensor, VIB 6.655

Item No.	Description	Application / Hint
VIB 6.657	Magnetic holder, 1/4-28 mounting hole	Magnetic coupling to the measurement location. Material: Stainless steel/Neodymium; Max. temperature: + 80°C
VIB 6.656	Magnetic holder, M6 mounting hole	Magnetic coupling to the measurement location. Material: Stainless steel/Neodymium; Max. temperature: + 80°C

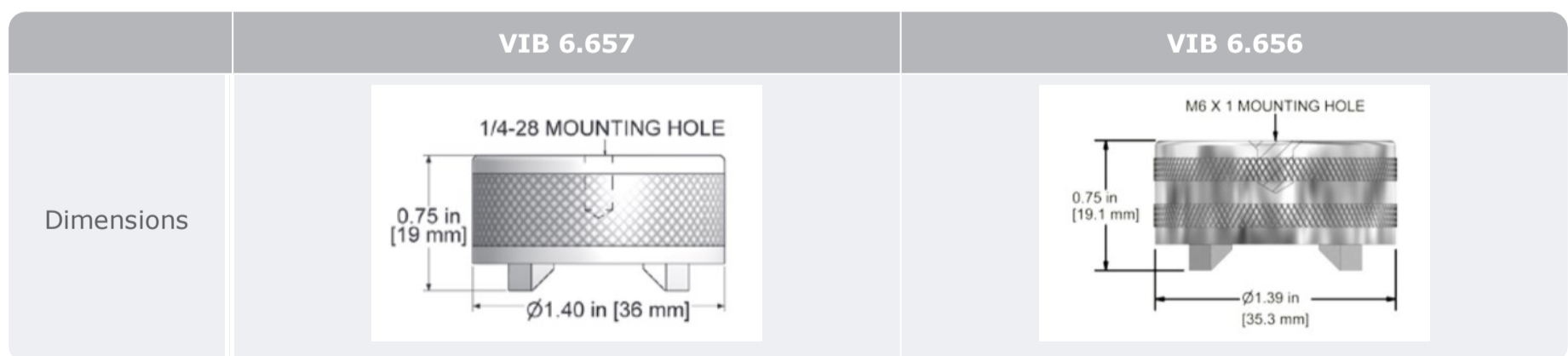

Accessories

Item No.	Item name / item group
Miscellaneous	"Tools for installation of accelerometers", p. 75

TECHNICAL INFORMATION

Technical data, Magnetic adapter

Parameter	VIB 3.420	VIB 3.422	VIB 3.423
Housing, material	Plastic PA6, pole shoe made of steel	Steel	
Block magnet	NdFeB (neodymium iron boron)		
Temperature range (for PA6)	-40°C ... +120°C	---	---
Connection thread	M5	¼-28 UNF	
Weight, total	70 g	27 g	41 g
Weight, magnet	28 g	5 g	7 g
Diameter	34 mm	20 mm	25 mm
Height	23 mm	11 mm	10 mm

Note: During transport/storage, a steel washer needs to be attached to the pole shoes as a short-circuit rail. The safety data sheet is available on the PRUFTECHNIK website.

Material and dimensions

All of the adapters listed below are made from stainless steel (VA1.4305). The dimensions are stated in millimeters.

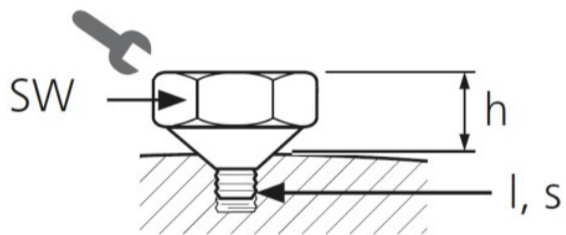

Item No.	Mounting height h	Thread size s	Thread length l	Torque in Nm	Wrench size SW
VIB 3.411	18	M8	6	11	20
VIB 3.412	17	M10	6	22	20
VIB 3.413	16	M12	6	39	20
VIB 3.417-M5	11	M5	5	2.7	13
VIB 3.417-M6	11	M6	6	4.6	13
VIB 3.418	6	---	---	---	---
VIB 3.430	16	---	---	---	---
VIB 3.431 / 3.432	21	---	---	---	---
VIB 3.433	8	---	---	---	---
VIB 3.435	8	M5-120°	3.5	2.7	19
VIB 3.436	8	M6-90°	6	4.6	19
VIB 3.437	4	M8-90°	5	11	---
VIB 3.438	8	M8	4	11	22

Item No.	Mounting height h	Thread size s	Thread length l	Torque in Nm	Wrench size SW
VIB 3.439	1	M5	4	2.7	---
VIB 3.440	9	M8-90°	5	11	19
VIB 3.480	0	M8	11	11	---
VIB 8.772	12	M10-120°	7	22	19

Mounting examples

Screw adapter with lock nut

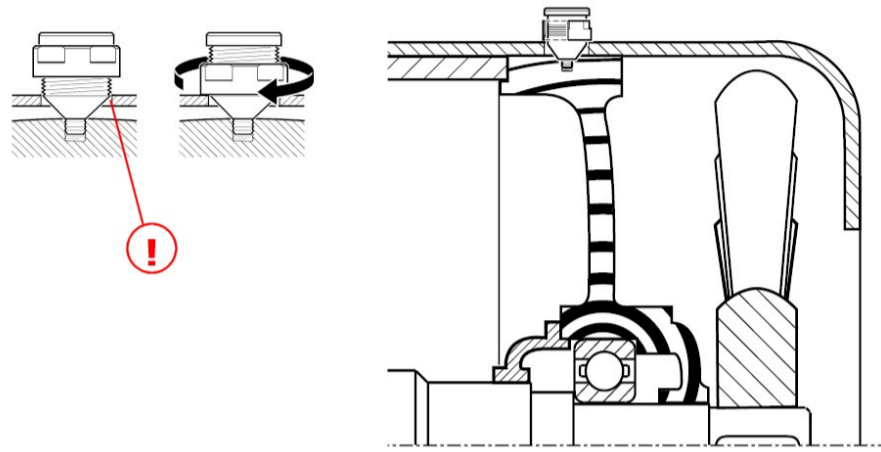

!: No contact between the adapter and cover.

The lock nut fixes the cover in place while the screw adapter is bolted to the measurement location. For optimum transmission of the signal, the cone must only come in contact with the measurement location and must not come in contact with the cover.

Extension rod

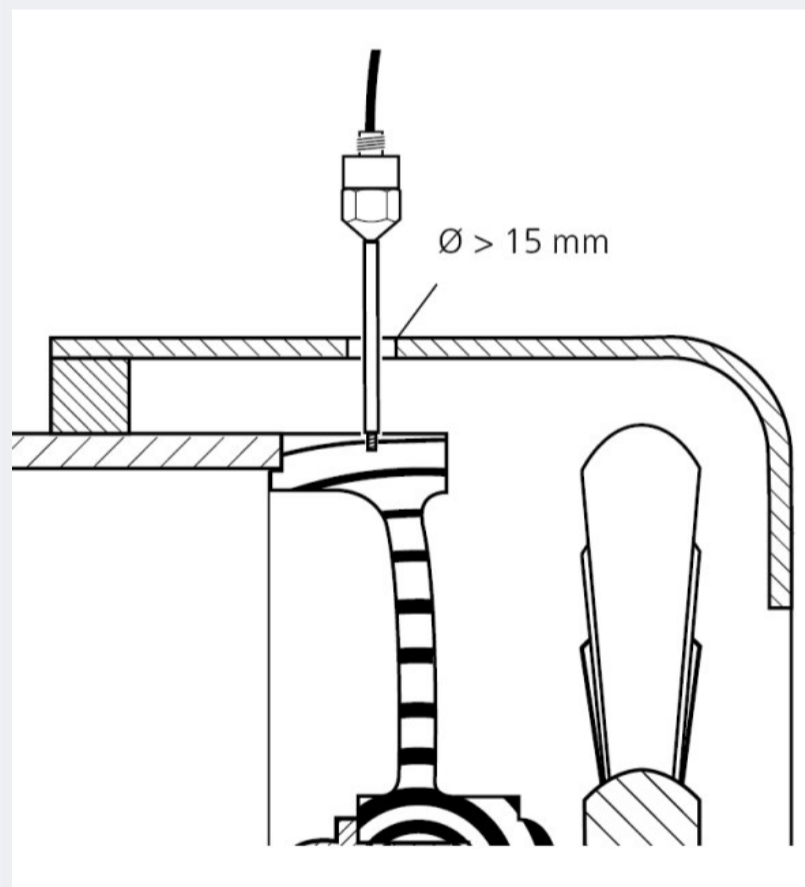

!: No contact between the extension rod and cover.

Pre-assembled sensor cables and adapters for CLD accelerometers (portable devices)

These cables and adapters are used to connect CLD accelerometers to portable devices.



Sensor VIB 6.142 connected to VIBXPERT II using the spiral connection cable VIB 5.436



Suited for following portable devices:

- VIBXPERT II, VIBXPERT EX
- VIBSCANNER, VIBSCANNER EX
- VIBGUARD portable

Suited for following types of sensors:

- CLD accelerometers with TNC cable connection
- "Wind" CLD accelerometer VIB 6.195

Ordering information

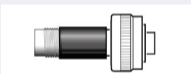
Item No.		Description
VIB 5.436		CLD accelerometer cable, spiral, 1.8 m, TNC connector to MiniSnap
VIB 5.437-2,9 VIB 5.437-5		CLD accelerometer cable, straight, 2.9 m or 5 m, TNC connector to MiniSnap
VIB 5.449-CLD		Adapter used to connect VIB 6.195 to portable measuring devices, 2-pin MIL-C5015 plug to TNC socket

Note: For cable lengths greater than 2.9 m, the EMC immunity of the signal path can be adversely affected.

TECHNICAL INFORMATION

Accessories

Item No.	Description
Miscellaneous	"Extension cable for analog measuring channel, portable devices", p. 30

Compatibility overview: Sensor cable – Measurement device

The following overview shows the type of sensor cable that may be connected to the corresponding device. For cables marked with (*), additional cables and/or adapters are required in the measurement chain.

Cable / Adapter	VIBXPERT II	VIBXPERT EX	VIBSCANNER	VIBSCANNER EX	VIBGUARD portable
VIB 5.436	✓	✓	✓	✓	✗
VIB 5.437-2,9 / -5	✓	✓	✓	✓	✗
VIB 5.449-CLD*	✓	✗	✓	✗	✓

Extension cable for analog measuring channel, portable devices

These sensor cables and adapters are used for connecting vibration sensors with current output (CLD) to portable measuring devices.

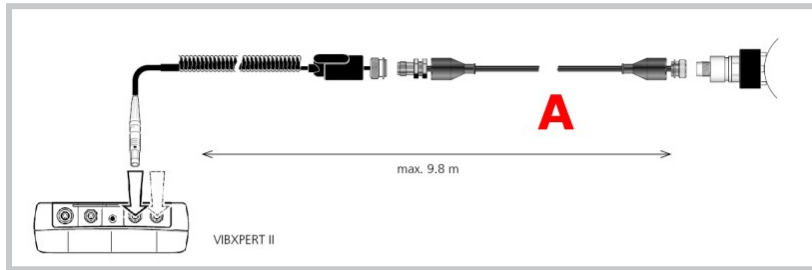



Sensor VIB 6.142 with extension VIB 5.339 (A) and spiral cable VIB 5.436 connected to VIBXPERT II.

Compatible with the following measuring devices:

- VIBXPERT II, VIBXPERT EX
- VIBSCANNER, VIBSCANNER EX

Ordering information

Item No.		Description
VIB 5.444-5		Extension cable for analog measuring channel, 5 meters, MiniSnap socket to MiniSnap plug
VIB 5.339		Extension cable for analog measuring channel, 8 meters, TNC plug to TNC socket

Note: For cable lengths greater than 2.9 meters, EMC interference resistance of the measuring section may be impaired.

TECHNICAL INFORMATION

Compatibility overview: Sensor cable – extension

The following overview shows, which sensor cable/ adapter can be used with which extension cable.

Sensor cable/adapter	Extension VIB 5.339	Extension VIB 5.444-5
VIB 5.436	✓	✓
VIB 5.437-2.9	✓	✓
VIB 5.437-5	✓	✓
VIB 5.438-0.5	✗	✓
VIB 5.422	✗	✓
VIB 5.433	✗	✓
VIB 5.433 X	✗	✓
VIB 5.434	✗	✓
VIB 5.342	✗	✓
VIB 5.346	✗	✓

Laser trigger / RPM sensor

This laser optical sensor is used in combination with a handheld device to act as a trigger for vibration measurements and to measure RPM.



Features

- Optical measurement method
- Contactless measurement
- Wider measurement range
- Measurement distance up to 1 m (39 1/3")
- High accuracy

Ordering information

Item No.	Description
VIB 6.631	Laser trigger / RPM sensor

Accessories

Item No.	Description
Miscellaneous	"Pre-assembled sensor cable and adapter for trigger / RPM sensor (portable devices)", p. 35
Miscellaneous	"Stand and accessories for laser trigger / RPM sensor", p. 33

TECHNICAL INFORMATION

Technical data

Parameter	VIB 6.631 / VIB 6.631 EX
MEASUREMENT	
Measurement principle	Optical
Measurement range	3 to 120'000 1/min.
Measurement distance with reflective mark	5 – 100 cm [2" - 39 1/3"]
Measurement distance with contrast mark	5 – 20 cm [2" - 7 7/8"]
Temperature range	-20 °C to 50 °C (-4 °F to 122 °F)
ELECTRICAL	
Power supply	< 5.8 V (from device)
Output	5 V (TTL)
Laser wavelength	630-680 nm (red)
Laser class	2 (DIN EN 60825-1, May 2014)
MECHANICAL	

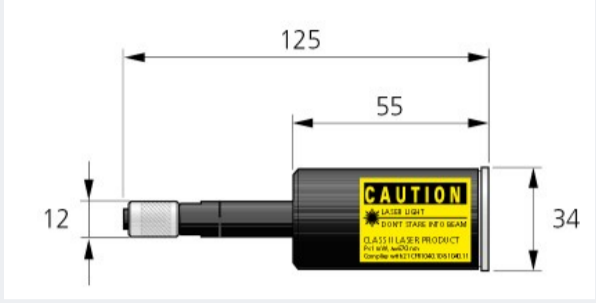
Parameter	VIB 6.631 / VIB 6.631 EX
Environmental protection	IP 65 with cable connector locked
Mounting	With stand and magnetic holder
Cable connection	Binder socket
Weight	76 g
Dimensions	

Stand and accessories for laser trigger / RPM sensor

This stand is used to mount securely the laser trigger sensor on machines. The sensor may be adjusted to virtually any position using the ball joint on the stand. The magnetic holder on the stand ensures that the setup of the measuring components remains fixed on any magnetic surface. The reflective tape serves as a measurement mark on the rotating shaft.



Stand and reflective tape

Features

- Secure and stable mounting of sensor
- Mounts readily even on curved surfaces
- 360° sensor adjustment
- Compact structural shape

Ordering information

Item No.	Description
VIB 6.632	Stand for laser trigger / RPM sensor
VIB 3.306	Reflective tape, 10 mm wide in a roll (4.5 m)

TECHNICAL INFORMATION

Technical data

Parameter	VIB 6.632
Weight	approx. 230 g
Mounting height	Max. 116 mm
Fixation	Magnetic; Block magnet: NdFeB

Note: During transportation or storage, a washer-shaped steel plate is placed on the pole pieces to act as a short-circuit rail. The relevant safety data sheet is available for download and reference from the PRÜFTECHNIK website.

Installation example



RPM sensor mounted on the stand



Measuring RPM: Stand (1), the reflective tape is on the shaft (2) and RPM sensor (3).

Pre-assembled sensor cable and adapter for trigger / RPM sensor (portable devices)

The sensor cable and adapter are intended for transmitting digital signals from e.g. a trigger or an RPM sensor.









Suited for following portable devices:

- VIBXPERT II / VIBSCANNER
- VIBXPERT EX / VIBSCANNER EX
- VIBGUARD portable

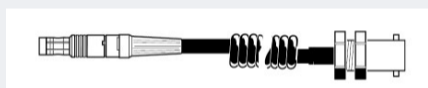
Sensor cable for laser trigger / RPM sensor VIB 6.631 connected to VIBXPERT II

Ordering information

Item No.		Description
VIB 5.432-2,9		Sensor cable for laser trigger / RPM sensor VIB 6.631, straight, 2.9 m, Binder socket to MiniSnap
VIB 4.750-5		Extension for sensor cable VIB 5.432-2,9, straight, 5 m, Binder socket to Binder plug
VIB 5.443		Sensor cable for TTL trigger (other manufacturer), spiral, 1.6 m, BNC socket to MiniSnap
VIB 5.332 X		Keyphasor adapter for machine protection systems (VIBXPERT II, VIBXPERT EX, VIBSCANNER, VIBSCANNER EX), Binder socket to BNC socket
VIB 5.333		Connection adapter for LED stroboscope VIB 6.672 (VIBXPERT II), Binder socket to BNC socket
VIB 7.832-5		Sensor cable for laser trigger / RPM sensor VIB 6.631, straight, 5 m, Binder socket to M12 Binder plug (VIBGUARD portable)

TECHNICAL INFORMATION

Technical data

Parameter	VIB 5.332 X
ELECTRICAL	
Operating voltage	5.4 V ± 10%
Current consumption	0.5 mA
Input signal, Pulse width	> 100 µs
Input signal, Pulse level	> 500 mV _{pp}
Input signal, DC portion	+8 V to -30 V
Output signal	5 V, rectangular signal
Input resistance	200 kOhm
Output resistance	1 kOhm
MECHANICAL	
Case material	Stainless steel, VA 1.4301
Length including connectors	130 mm
Diameter	15 mm
Weight	30 g
Environmental protection	IP 65
Temperature range	0 °C to 40 °C (32 °F to 104 °F)
CONNECTIONS	
Input signal	Binder connector, 8-pin, 712 series
Input signal, Pin allocation	2: 5 V / 4: Rectangular signal / 7: GND
Output signal	BNC socket
Output signal, Pin allocation	Internal contact: Signal / External contact: GND

Note: This adapter converts a pulse signal (including the DC level) to a 5V rectangular signal. This allows keyphasors that are connected to a machine protection system be connected and operated by PRÜFTECHNIK instruments.

When feeding digital signals to either the intrinsically safe VIBXPART EX or the intrinsically safe VIBSCANNER EX, the adapter **VIB 5.332 X** must be used. The adapter protects the digital port on the measuring instrument against overvoltages. The adapter must only be connected outside an explosive atmosphere to an electrical circuit, whose maximum voltage does not exceed 265 V_{eff.} even when a malfunction occurs. The permissible ambient temperature is 0 °C to 40 °C (32 °C to 104 °C).

Technical data, VIB 5.333

Parameter	VIB 5.333
Case material	Aluminium
Length including connectors	62 mm
Diameter	15 mm
Weight	20 g

Compatibility overview: Sensor cable – Measurement device

The following overview shows the type of sensor cable or adapter that may be connected to the corresponding device. For adapters marked with (*), additional cables are required in the measurement chain.

Sensor cable / Adapter	VIBXPert II	VIBXPert EX	VIBSCANNER	VIBSCANNER EX	VIBGUARD portable
VIB 5.432-2,9	✓	✓	✓	✓	✗
VIB 5.443	✓	✓	✓	✓	✗
VIB 5.332 X*	✗	✓	✗	✓	✗
VIB 5.333	✓	✗	✗	✗	✗
VIB 7.832-5	✗	✗	✗	✗	✓

Application example

VIBXPert II: RPM measurement using Laser trigger / RPM sensor VIB 6.631



A: Sensor cable VIB 5.432-2,9

b: Laser trigger / RPM sensor VIB 6.631

**VIBXPERT II: Shaft vibration measured as a voltage signal on a machine protection system
(e.g. Bently Nevada 3300)**

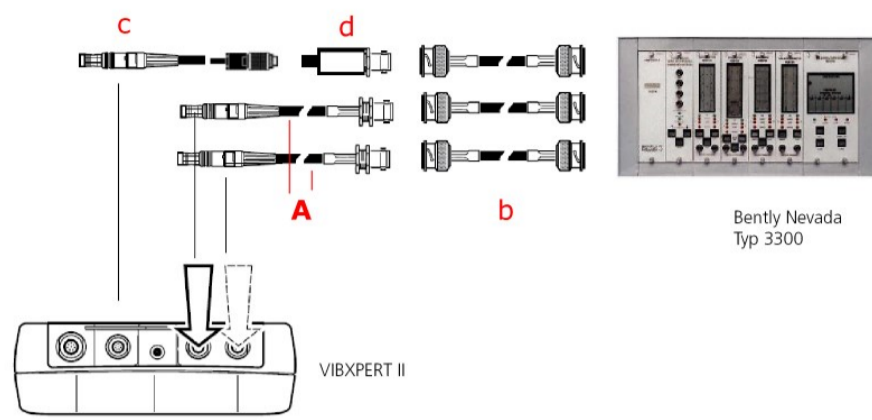

- A: Sensor cable for measurement of signal-low voltage VIB 5.433
(2 pieces)
- b: Coaxial cable with BNC connector, 3 pieces
- c: Sensor cable for trigger / RPM sensor VIB 5.432-2,9
- d: Keyphasor adapter VIB 5.332 X

VIBXPERT II: Measuring RPM using the LED stroboscope VIB 6.672

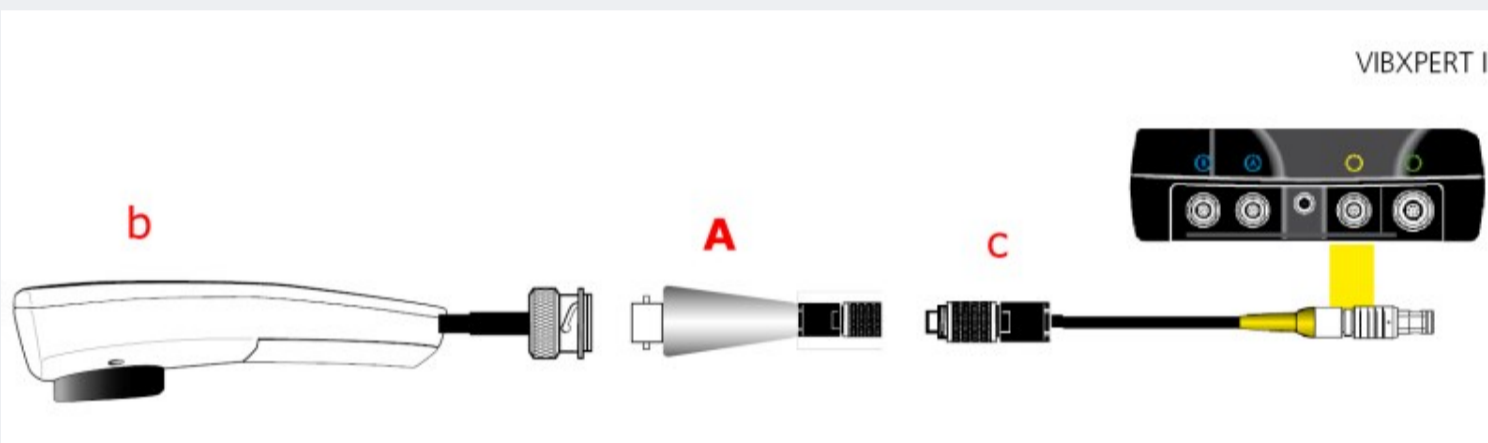

- A: Cable adapter for LED stroboscope, VIB 5.333
- b: LED stroboscope, VIB 6.672
- c: Sensor cable, VIB 5.432-2,9

Accessories

The following section provides detailed information about the components and the optional accessories.

Note: Some components are not suitable for use with VIBXPART II for technical reasons.

Charging station for VIBXPART II rechargeable battery	40
OMNITREND Center	41
OMNITREND PC Software	42
VIBXPART utility	44
VIBCODE vibration transducer	45
VIBCODE measurement studs	47
Accessories for VIBCODE measurement studs	50
Triaxial accelerometer	51
Displacement sensor for VIBXPART II	53
Temperature probes	55
IEPE-type accelerometers	56
Ethernet cable for VIBXPART II	59
Cable adapter for VIBXPART II	60
Connection cable for field multiplexer on VIBXPART II	62
Serial PC cables - RS232	63
Cables for signal output – handheld devices	65
Pre-assembled sensor cables for measuring low signal voltage/low signal current, portable measuring devices	66
Mono headphones	69
LED stroboscope	70
Current clamp (400 A AC / 600 A DC)	72
Tools for cable installation	74
Tools for installation of accelerometers	75

Charging station for VIBXPERT II rechargeable battery

Using this charging station, the VIBXPERT-II rechargeable battery is charged outside of the measuring device, while you can continue working with the VIBXPERT II and a second, fully charged rechargeable battery.

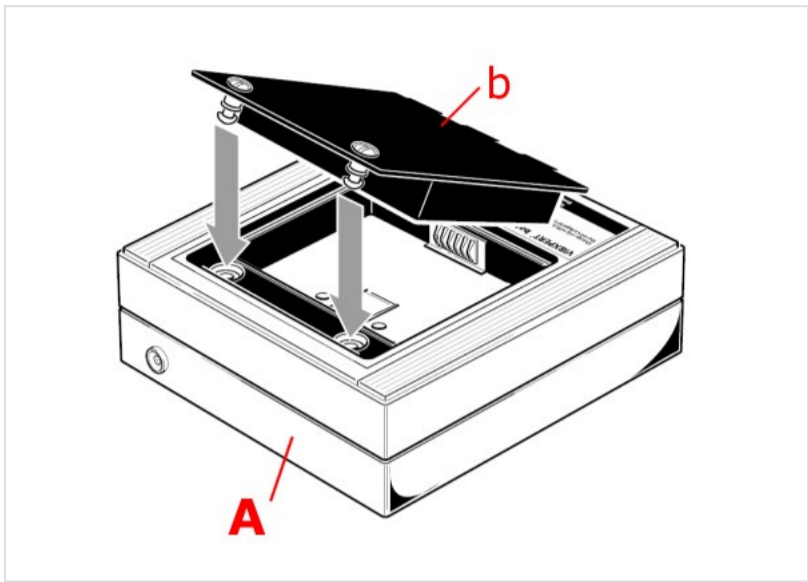

Charging station (A) for VIBXPERT II rechargeable battery (b).

Features

- LED display for battery status.
- Connection for VIBXPERT II charger
- Compact design
- Spare rechargeable battery available as accessory item

Ordering information

Item No.	Description
VIB 5.324	Charging station for VIBXPERT II rechargeable battery

TECHNICAL INFORMATION

Technical data

Parameter	Charger for VIBXPERT II rechargeable battery - VIB 5.324
Mains connection	MiniSnap socket for VIBXPERT II charger
Battery status displays	3 LEDs: green = charging completed; yellow = rechargeable battery is being charged; red = fault during charging
Charge temperature range	0 °C ... + 50 °C [32 ... 122 °F]
Charge time	< 5 hours
Dimensions	approx. 150 x 150 x 60 mm [5 7/8" x 5 7/8" x 2 3/8"]

OMNITREND Center

OMNITREND Center is the newly developed software platform for the following PRÜFTECHNIK measuring systems: VIBGUARD, VIBGUARD compact, VIBGUARD portable, VIBRONET Signalmaster, VIBROWEB XP, VIBXPERT II, VIBXPERT EX, VIBSCANNER 2.

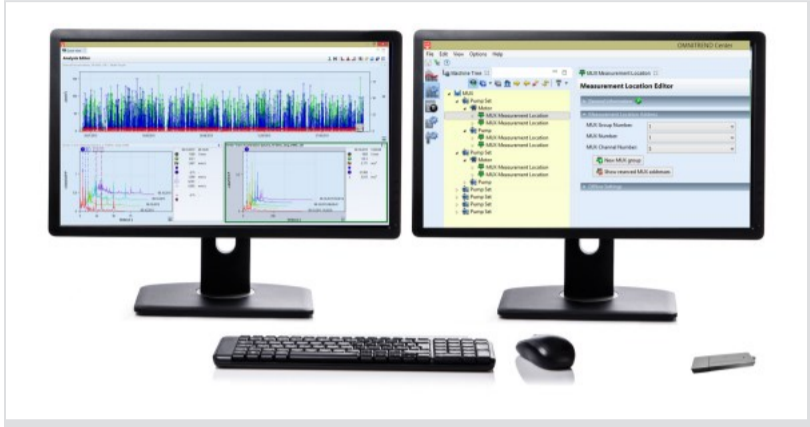

OMNITREND Center is multi-screen-capable.

Features

- Modern system architecture – ideal for distributed networks and cloud-based solutions
- Central data management
- Single-user and client-server version
- Advanced Modbus support
- Interactive report function
- User-friendly operation
- Multi-screen-capable
- Available in 13 languages
- Attractive license conditions
- Free software updates

Ordering information

Item No.	Description
VIB 8.200	OMNITREND Center, client-server version
VIB 8.210	OMNITREND Center, single user version
Licenses for user, database, server	
VIB 8.201/ 8.202	Floating user licenses: 1 / 5
VIB 8.203 / 8.204	Fixed user licenses: 1 / 5
VIB 8.205	10 additional database licenses
Licenses for functions	
VIB 8.207	Email Center

Notes: The scope of delivery comprises one USB flash drive each with software and license files, including installation and startup instructions in PDF format.

OMNITREND PC Software

OMNITREND is the universal software platform for all data-acquiring PRÜFTECHNIK measuring systems (stationary and portable).



OMNITREND PC software on CD-ROM.

Features

- Trend acquisition and forecast
- Comprehensive signal analyses
- Configurable reports
- Data exchange with CMMS systems
- User-friendly operation
- Available in 13 languages
- Attractive license conditions
- Free software updates

Ordering information

Item No.	Description
OMNITREND for VIBXPART II / VIBXPART EX	
VIB 8.981	OMNITREND for VIBXPART II, software package (incl. OMNITREND web single user)
VIB 8.982	OMNITREND View for VIBXPART II, software package
VIB 8.981-OMT	VIBXPART device driver for OMNITREND
VIB 5.312-P	PC license for VIBXPART II
VIB 8.981-P	PC license for VIBXPART EX
OMNITREND for VIBSCANNER	
VIB 8.955	OMNITREND for VIBSCANNER, software package
VIB 8.956	OMNITREND View for VIBSCANNER, software package
VIB 5.481	VIBSCANNER device driver for OMNITREND
VIB 5.480-P	PC license for VIBSCANNER
VIB 8.961	OMNITREND module "Gearbox Editor"
VIB 8.962	OMNITREND module "Signal Analysis"
OMNITREND for VIBROWEB XP	
VIB 7.780	OMNITREND for VIBROWEB XP, software package
VIB 7.780-DR	VIBROWEB-XP device driver for OMNITREND
VIB 7.780-P	PC license for VIBROWEB XP

Notes: Every software package and device driver contain a printed pocket guide and PC license in addition to a CD ROM.

A **device driver** is a file that enables the operation of an already present software with the respective device type.

A **PC license** is a password that enables communication between OMNITREND and the respective measuring device.

After initial installation, OMNITREND runs in demo mode. To enable the full version, a **registration password** is required, which must be requested by the user during startup.

TECHNICAL INFORMATION

OMNITREND for VIBSCANNER, "Signal Analysis" module

The OMNITREND "Signal Analysis" software module is available as extension of an already registered OMNITREND installation and enables display and analysis of the following VIBSCANNER measurements:

Software package	VIBSCANNER measurements
OMNITREND for VIBSCANNER	Time signal (multimode & route), Orbit (multimode)
OMNITREND View for VIBSCANNER	Recording data

By registering the "Signal Analysis" module, the "Gearbox Editor" module is enabled as well.

VIBXPERT utility

This practical utility for the family of VIBXPERT devices supports the user during data transfer, data management and reporting. The software is available for downloading free of charge on the PRÜFTECHNIK website. Paid functions can be activated via password.



Export measurement data as MS Excel file with VIBXPERT utility.

Features

- Download of screenshots, PDF files
- Backup & restore
- Transfer company logo to measuring device
- Formatting of CF memory card
- Firmware update
- Data export into CSV format
- Data export into Excel format (optional)
- Data export into UFF / IEEE (optional)

Ordering information

Item No.	Description
VIB 8.984	VIBXPERT utility - Advanced File Export (UFF, IEEE)
VIB 8.986	VIBXPERT utility - Excel Report Module

Notes: The **Advanced File Export** function comprises the conversion of spectra, time signals, as well as measurement results of impact tests and phase measurements into the UFF resp. IEEE file format for analysis in other analysis programs.

Using the **Excel Report Module**, you can export the following measurement data into a formatted MS Excel file:

Characteristic overall value, FFT spectrum, balancing result, time signal, coast-down measurement (amplitude-phase and characteristic overall value), 2-channel measurements.

The Excel files are based on templates that can be adjusted by the expert user as needed.

Version: Excel 2003, Excel 2007

VIBCODE vibration transducer

VIBCODE is an intelligent sensor system that identifies measurement points by use of coded measurement studs. The patented VIBCODE transducer is attached to the coded measurement stud locked using a bayonet catch. The rigid connection at the measurement point ensures a loss-free transmission of vibration signals, and bearing signals (shock pulse). The electronics within the handle amplifies the signal and transmits the measurement point data to the measurement device.



VIBCODE transducer with protective cap

Features

- Reliable identification of measurement point
- Foolproof assignment of measurement tasks
- Rigid Mounting
- Repeatable measurement results
- 3-in-1 sensor: housing vibration, shock pulse (condition of roller bearings), cavitation
- VIBCODE measurement points with a various mounting options

Ordering information

Item No.	Description
VIB 8.660	VIBCODE transducer

Accessories

Item No.	Description
Miscellaneous	"VIBCODE measurement studs", p. 47
Miscellaneous	"Pre-assembled sensor cables and adapters for CLD accelerometers (portable devices)", p. 29

TECHNICAL INFORMATION

Technical data

Parameter	VIB 8.660
MEASUREMENT	
Signaling system	Current Line Drive, 3.5 mA static current with superimposed AC signal
Transmission factor, ±4%	1.0 $\mu\text{A}/\text{ms}^{-2} \pm 3\%$ (Ref.: 159 Hz; 25 °C)
Frequency range, ± 5%	4 Hz to 6 kHz
Frequency range, ± 10%	2 Hz to 10 kHz
Frequency range, ± 3dB	1.5 Hz to 20 kHz

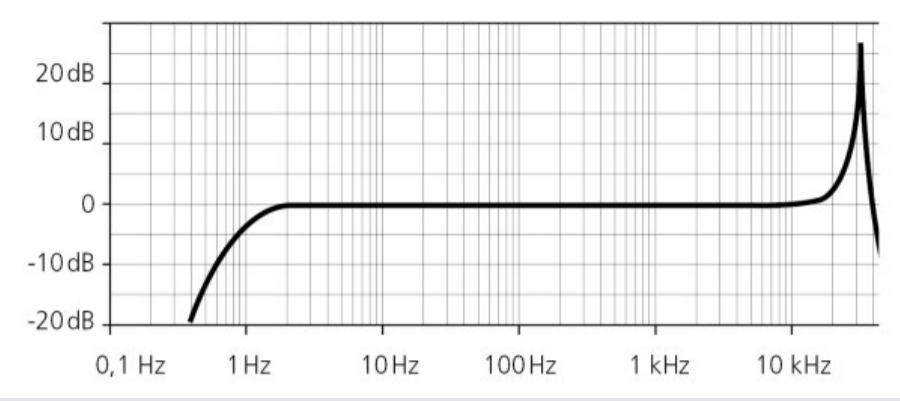
Parameter	VIB 8.660
Resonance frequency	36 kHz
Frequency response	
Linearity range, ± 10%	± 50 ms ⁻² (±5 g)
Temperature range	-10 °C to 70 °C (14 °F to 158 °F)
ELECTRICAL	
Power supply	> 10 mA / 7-18 VDC
Temperature transient sensitivity	< 0.3 ms ⁻² /K
Transverse sensitivity	< 10% of axial value
Magnetic field sensitivity	< 14 ms ⁻² /T (at 50 Hz)
Electrical noise	< 1 mms ⁻² / Hz ^{1/2} at 10 Hz
Output impedance	> 500 kOhm
MECHANICAL	
Environmental protection	IP 65 with cable connector locked
Mounting	VIBCODE measurement stud
Cable connection	coaxial, TNC
Weight	390 g
Dimensions	136 x 39 mm (hxd)

VIBCODE measurement studs

VIBCODE measurement studs are the standard measurement locations used with VIBCODE transducer. They provide a rigid connection to the object being measured, and each has a unique code. They are optimized for a loss-free signal transmission to the transducer. The measurement studs are available in different shapes.



Features:

- Guarantees a rigid connection to the transducer
- Facilitates repeatability in measurement results
- Foolproof identification of measurement points
- Coding of measurement points patented



Mounting options

- Screw mounting
- Glue mounting

VIBCODE measurement stud comprises stud, code ring and protective cap

Ordering information

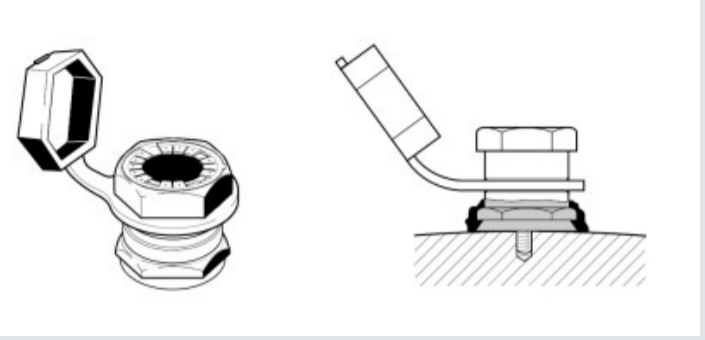
Item No.	Illustration	Description
VIBCODE measurement studs with threaded bolts		
VIB 8.679 SET		M8, VA 1.4571, 1 x Application / Hint: Standard stud, mounted using M8 threads in aggressive chemical industrial environment
VIB 8.680 SET VIB 8.680 A25		M8, VA 1.4305, 1 x/ M8, VA 1.4305, 25 x Application / Hint: Standard stud, mounted using M8 threads in normal industrial environment
VIB 8.690 SET VIB 8.690 A25		UNC 5/16, VA 1.4305, 1 x/ UNC 5/16, VA 1.4305, 25 x Application / Hint: Standard stud, mounted using UNC 5/16 in normal industrial environment

Item No.	Illustration	Description
VIBCODE measurement studs for adhesive mounting		
VIB 8.685 SET VIB 8.685 A25		1 x/ 25 x Application / Hint: For measurement points where mounting holes cannot be drilled. Fix using a two-component adhesive (e.g. WEICON HB 300). Mounting hint: A removable centering pin with self-tapping threads holds the stud in place until the adhesive hardens. Material: Stainless steel, VA1.4305
VIBCODE measurement studs with extension post		
VIB 8.576 VIB 8.577 VIB 8.578		M8 x 55 mm (2 3/16")/ M8 x 95 mm (3 3/4")/ M8 x 170 mm (6 11/16") Application / Hint: Measurement stud for measurement points that are difficult to access or where standard studs cannot be directly mounted. The longest version (170 mm / 6 11/16") is suited for shock pulse measurements. Vibration measurements cannot be made using this type of stud as the length of the extension post increases the vibration amplitude. Material: Stainless steel, VA 1.4305
VIBCODE measurement studs with locking nut		
VIB 8.571 VIB 8.572 VIB 8.573		locking nut, M8 / locking nut, M10 / locking nut, M12 / Application / Hint: Measurement stud for measurement points protected with a thin guard or housing; the locking nut is tightened against the housing (or guard) and the measurement stud is screwed to the measurement position. To ensure optimum signal transmission, the cone of the stud may touch only the measurement point (e.g. the bearing housing), but not the metal casing. The VIBCODE measurement studs may be used to replace the used housing screws. Material: Stainless steel, VA 1.4305

Accessories

Item No.	Description / Group
Miscellaneous	"Accessories for VIBCODE measurement studs", p. 50
Miscellaneous	"Tools for installation of accelerometers", p. 75

TECHNICAL INFORMATION

Mounting height

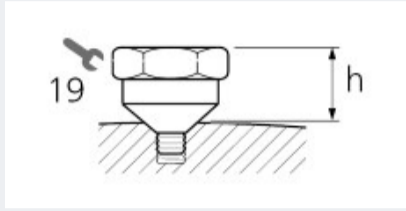
Item No.	Mounting height h in mm	Illustration
VIB 8.679../680../690..	15	
VIB 8.571 /..72 /..73	28 / 27 / 26	
VIB 8.685..	21	

Mounting example

VIBCODE measurement stud with locking nut

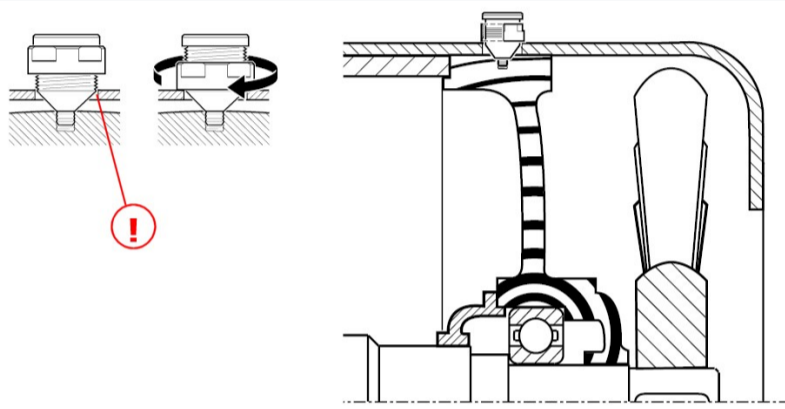

! : No contact between measurement point and protective cover
 The locking nut is tightened against the housing (or guard) and the measurement stud is screwed to the measurement position. To ensure optimum signal transmission, the cone of the stud may touch only the measurement point, but not the metal casing.

Extension post

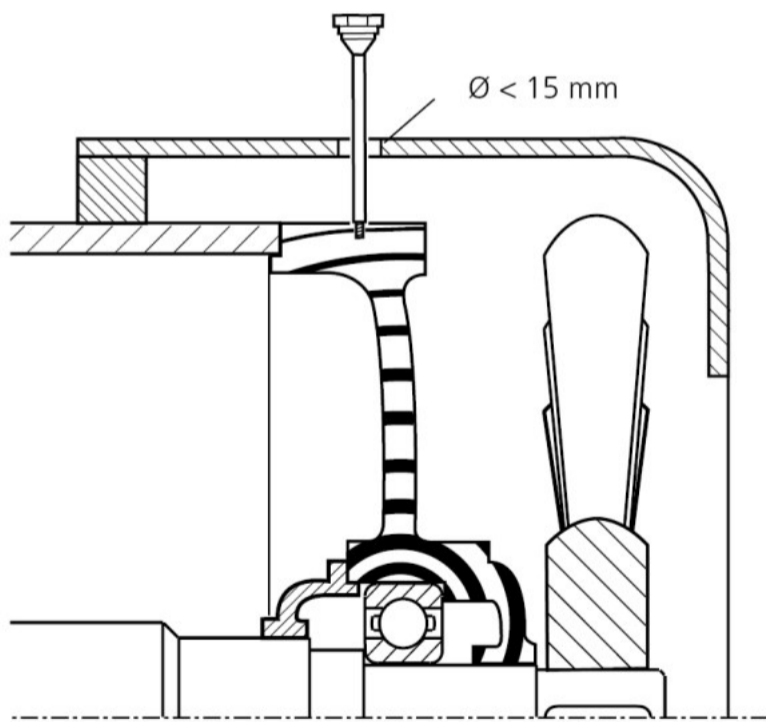

! : No contact between the extension post and the protective cover

Accessories for VIBCODE measurement studs

These items are used as consumables and to code VIBCODE measurement studs.



Protective cap, code ring, and encoding tool

Features

- Patented, measurement point coded mechanically
- Over 8000 different coded patterns possible
- Measurement point protected from contamination
- Easy encoding using a cutting tool

Ordering information

Item No.	Description
VIB 8.563 A25	VIBCODE code ring, 25 pieces
VIB 8.566	Protective cap for VIBCODE stud
VIB 8.692	VIBCODE encoding tool

TECHNICAL INFORMATION

Technical data

Parameter	Protective cap - VIB 8.566	Code ring - VIB 8.563
Material	Desmopan®	Hostaform®
Temperature range	-30 °C ... + 100 °C [-22 °F ... + 212 °F]	-40 °C ... + 130 °C [-40 °F ... + 266 °F]
Resistance	Oil, Coolant	

Application example, encoding tool

How to use the encoding tool:

- Insert code ring
- Insert the cutting tool
- Set code number (issued from OMNITREND software)
- Slowly press down the cutting tool

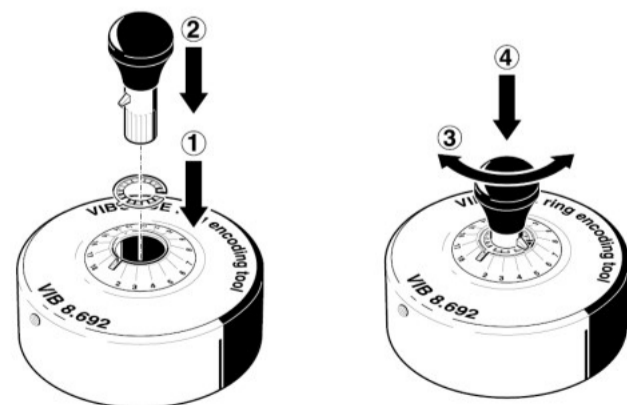

Triaxial accelerometer

This triaxial accelerometer is used for the measurement of machine and component vibrations in the horizontal, vertical and axial directions at a single measurement location. The triaxial accelerometer achieves shorter measuring times with a data collector and is easier to install since only one sensor needs to be mounted.



Features

- Simultaneous measurement in the X, Y, and Z axes
- Larger temperature range
- f_{\max} : 10 kHz
- For VIBXPART II and VIBSCANNER 2

Triaxial sensor for VIBXPART II

Ordering information

Item No.	Description
VIB 6.655	Triaxial accelerometer for mobile applications

Accessories

Item No.	Description
VIB 5.336	Sensor cable for triaxial accelerometer VIB 6.655; refer to: "Cable adapter for VIBXPART II", p. 60
VIB 6.656	Magnetic holder - M6 mounting hole, p. 26
VIB 6.657	Magnetic holder - 1/4-28 mounting hole, p. 26

TECHNICAL INFORMATION

Technical data

Parameter	VIB 6.655
MEASUREMENT	
Signaling system	IEPE
Measurement range (peak)	± 50 g
Transmission factor, $\pm 5\%$	100 mV/g
Frequency range, $\pm 5\%$	8 Hz to 5.5 kHz
Frequency range, $\pm 10\%$	1 Hz to 6.5 kHz

Parameter	VIB 6.655
Frequency range, $\pm 3\text{dB}$	0.6 Hz to 10 kHz
Temperature range	-54 °C to 121 °C (-65 °F to 250 °F)
ELECTRICAL	
Rise time	< 2.5 s
Power supply	2-10 mA / 18-30 VDC
Electrical noise, @ 10 / 100 / 1000 Hz	27 / 6.5 / 2.5 $\mu\text{g} / (\text{Hz})^{1/2}$
Output impedance	< 100 Ohm
Case insulation	> 10^8 Ohm
Output bias	11-13 VDC
MECHANICAL	
Case material	Stainless steel 316L
Mounting	Magnetic holder with M6 or 1/4-28 thread
Mounting torque	1.4 to 2.7 Nm
Connection	4-pin cable connector (Mini-MIL)
Weight	200 g
Dimensions	35 x 35 x 24 mm / 1.4" x 1.4" x 0.9" (lxbxh)

Connection schematic

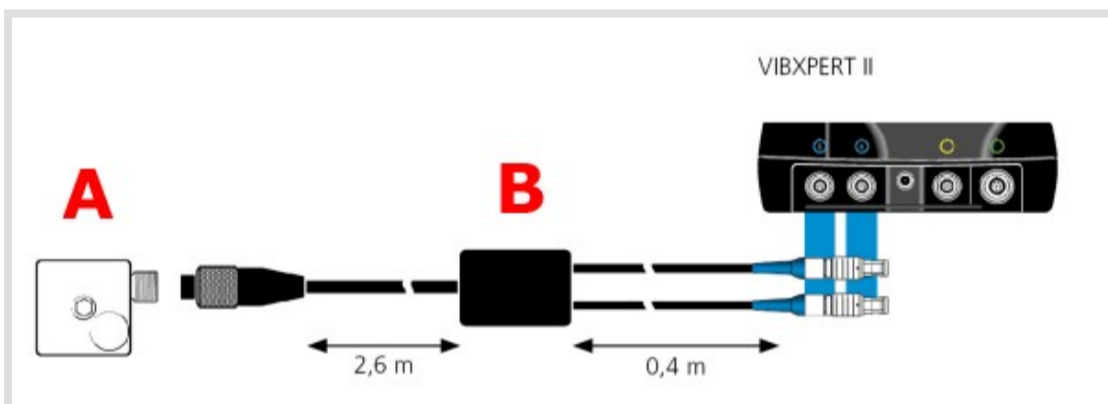

Triaxial sensor (A) connected to VIBXPRT II via the sensor cable (B)

Mounting example



Displacement sensor for VIBXPERT II

This displacement sensor is used with VIBXPERT II to determine the position of metallic objects within close proximity to each other, contactless. A typical application is the detection of the radial and axial motions of a rotating shaft.



Displacement sensor connected to VIBXPERT II

Features

- Inductive measurement
- Working range: 3 - 15 mm
- Easy to mount and position
- Connection cable with device connector
- Linearization of the characteristic curve is automatically done within device

Ordering information

Item No.	Description
VIB 6.640	Inductive proximity sensor for VIBXPERT II

TECHNICAL INFORMATION

Technical data

Parameter	VIB 6.640
MEASUREMENT	
Measurement principle	Inductive
Measurement variable	Relative distance / displacement
Working range S_n	3 – 15 mm
Linearity	$\leq 5\%$
Repeatability	$\leq 1\%$
Average rise	0.333 V/mm $\pm 5\%$
Cut-off frequency	300 Hz
Influence on the operating voltage dU_a/dU_b	approx. 6.7% / 0.1 V
Temperature range	-25 °C to 70 °C (-13 °F to 158 °F)
Temperature drift	$\pm 5\%$
ELECTRICAL	
Operating voltage U_b	5 VDC, stabilized
Operating current	$\leq 15\text{mA}$
Output signal U_a	approx. 0.5 to 4.5 VDC (refer to characteristic)
Load resistance	$\geq 20\text{k}\Omega$
MECHANICAL	
Case material	Nickel-plated brass

Parameter	VIB 6.640
Material of active surface	PCP
Environmental protection	IP 67
Mounting	Non-flush
Connection cable	cable with MiniSnap device connector, 2.9 m

Hint for mounting: When carrying out non-flush mounting on metal surfaces, observe the following hint according to EN 60947-5-2.

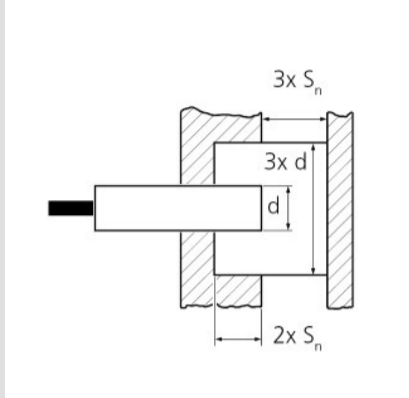

Characteristic

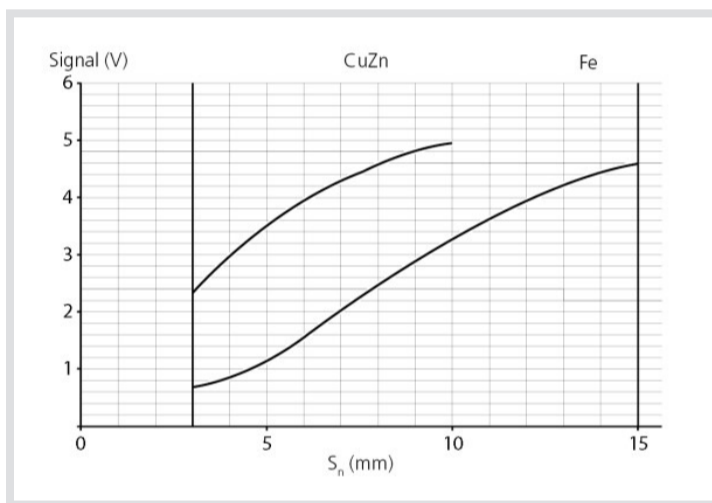

Dimensions

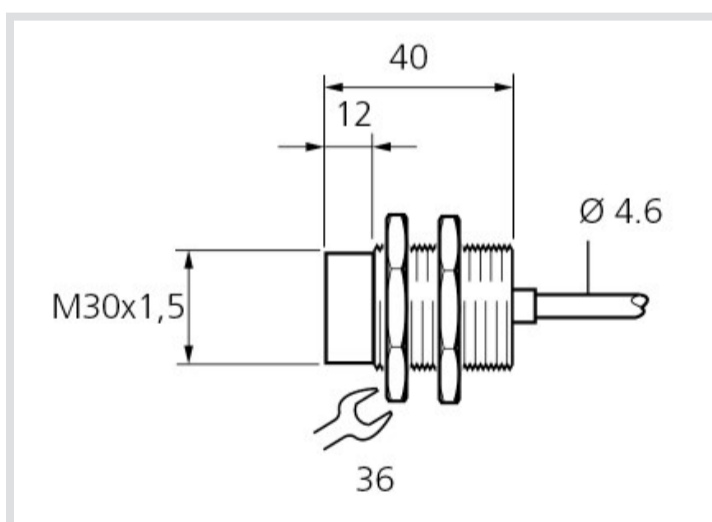

Connection diagram

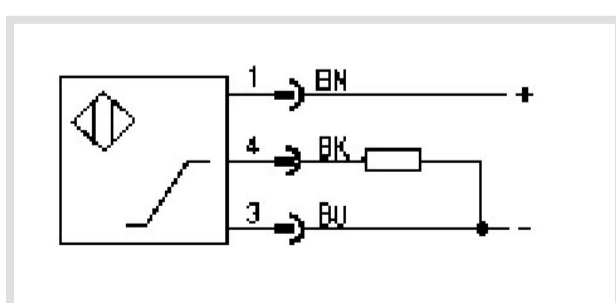

Temperature probes

These sensors are used in conjunction with handheld devices to measure temperature also in hazardous areas.



Temperature probe with magnetic holder

Features

- NiCrNi thermocouple
- Compact shape
- High temperature version, $T_{max.} : 500^{\circ}\text{C}$ (932 °F)
- Used together with intrinsically safe measurement devices

Ordering information

Item No.	Illustration	Description
VIB 8.605		Spare temperature probe for VIBSCANNER
VIB 8.607-1,5		Temperature probe with magnetic holder, 1.5 m
VIB 8.608		Temperature handheld probe

TECHNICAL INFORMATION

Technical data

Parameter	VIB 8.605	VIB 8.607-1,5	VIB 8.608
MEASUREMENT			
Type of sensor	NiCrNi thermocouple		
Measurement range	-30 °C to 270°C (-22 °F to 518 °F)	-50 °C to 240 °C (-58 °F to 464 °F)	-50 °C to 500 °C (-58 °F to 932 °F)
Sensitivity	---	0.040 mV/°C	
Accuracy	< 3%		
MECHANICAL			
Dimensions (L x Ø)	25 x 11 mm (63/64" x 7/16")	14 mm (35/64") - (Ø)	250 x 3 mm (9 27/32" x 1/8")
Length of cable	---	1.5 m (4' 11")	---
Weight	6 g (0.2 oz)	28 g (1 oz)	83 g (2.9 oz)
Connector	QLA		

Note: When transporting or storing the temperature probe with magnetic holder a steel washer is mounted on the pole pieces to act as a short circuit rail. The relevant safety data sheet is available on www.pruftechnik.com

IEPE-type accelerometers

These sensors are suited for measurement of absolute machine vibrations in industrial environments. Due to the very low cutoff frequency, they are particularly suitable for very slowly rotating machinery components such as the main bearings of a wind turbine.

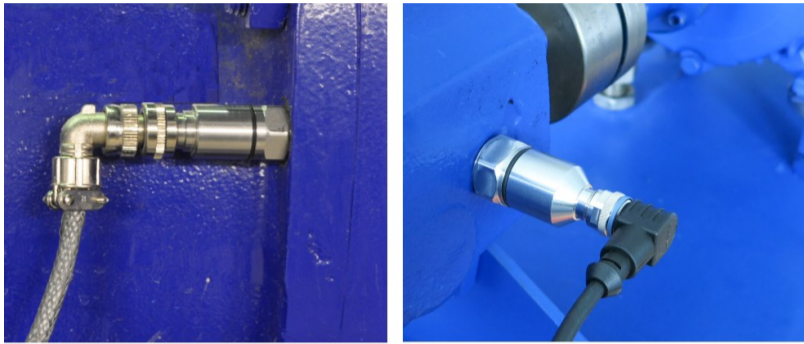

Sensor with MIL connector (left) and M12 connector (right).

Features

- Voltage output according to IEPE standard
- $f_{\min.} : 0.1 \text{ Hz}$
- Two connector types: M12 or MIL
- IP 67 when cable connector is locked
- Permanent installation on the machine
- High temperature version, $T_{\max.} : 120^{\circ}\text{C}$

Ordering information

Item No.	Description
VIB 6.172	Accelerometer (IEPE) with MIL connector
VIB 6.210	Accelerometer (IEPE) with M12 connector

Accessory

VIB 6.172 is delivered together with an M8 hexagon socket set screw. The set screw may be replaced using the available optional mounting adapters. In VIB 6.210, the mounting threads are fixed to the sensor casing.

Item No.	Description / Group
Miscellaneous	"Mounting adapters for vibration sensors", p. 24
Miscellaneous	"Sensor cable with 2-pin MIL connector", for VIB 6.172
VIB 3.575-L	"Sensor cable with 4-pin M12 connector", for VIB 6.210
VIB 5.449-ICP	"Cable adapter for VIBXPRT II", p. 60

TECHNICAL INFORMATION

Technical data

Parameter	VIB 6.172	VIB 6.210
MEASUREMENT		
Signalling system	IEPE	
Transmission factor, $\pm 4\%$	10.2 mV/ ms^{-2} (100mV/g); Ref.: 159 Hz; 25 °C / 77 °F	
Frequency range $\pm 5\%$	1 Hz to 6 kHz	
Frequency range $\pm 10\%$	0.5 Hz to 8 kHz	
Frequency range $\pm 3\text{dB}$	0.1 Hz to 10 kHz	
Resonance frequency	17 kHz; > 10 dB damped	15 kHz; > 10 dB damped

Parameter	VIB 6.172	VIB 6.210
Frequency response		
Linearity range, $\pm 10\%$	$< 686 \text{ ms}^{-2}$ ($< 70 \text{ g}$)	
Temperature range	$-40 \text{ }^\circ\text{C}$ to $120 \text{ }^\circ\text{C}$ ($-40 \text{ }^\circ\text{F}$ to $248 \text{ }^\circ\text{F}$)	$-40 \text{ }^\circ\text{C}$ to $85 \text{ }^\circ\text{C}$ ($-40 \text{ }^\circ\text{F}$ to $185 \text{ }^\circ\text{F}$)
ELECTRICAL		
Power supply	2 - 10 mA / 24 V DC ($\pm 10\%$)	2 - 10 mA / 18 - 30 V DC
Bias, DC output	12 V DC $\pm 0,5 \text{ V}$	
Grounding	insulated from machine ground, internal shielding	
Transverse sensitivity	$< 5\%$	
Temperature transient sensitivity	$< 0.07\%/K$	
Magnetic field sensitivity	$< 1 \text{ ms}^{-2}/T$ (at 50 Hz)	
Base strain sensitivity	$< 0.1 \text{ m/s}^2/\mu\text{m/m}$	
Electrical noise, rms	1 mm/s^2 (0.1 Hz - 10 kHz)	1.5 mm/s^2 (0.1 Hz - 10 kHz)
Output impedance	$< 10 \text{ Ohm}$	$< 100 \text{ Ohm}$
MECHANICAL		
Case material	Stainless steel VA 1.4305	
Environmental protection	IP 67 with cable connector locked	
Mounting	M8 threaded screw or mounting adapter	
Cable connector	2-pin MIL-C5015	M12, 4-pin, A-coded
Shock limit	$< 50 \text{ km/s}^2$	
Weight	85 g (3 oz)	72 g (2.5 oz)
Mounting height, mm		

Pin allocation

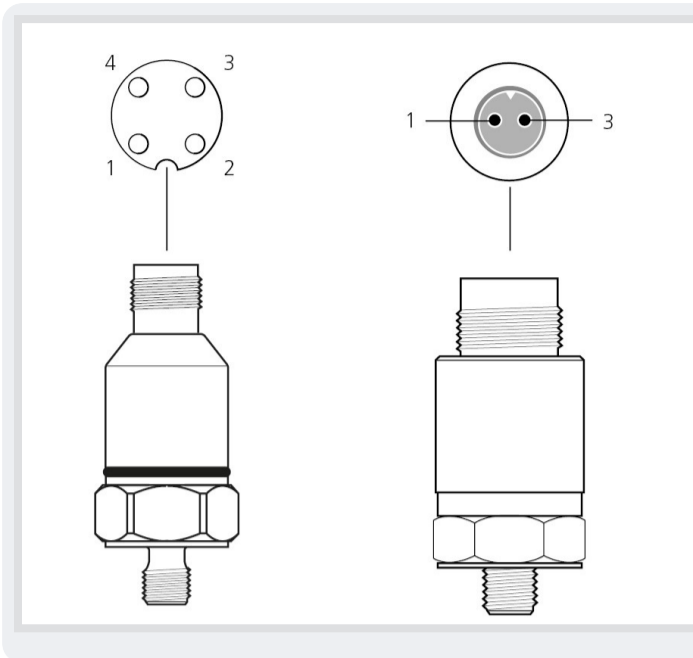

1: Signal (+)

3: GND (-)

2,4: nc

Ethernet cable for VIBXPERT II

This cable is used for data transmission within a network.



Ethernet cable connected to VIBXPERT II

Features

- The patch cable is used to connect measurement devices to network sockets
- FTP CAT.5 patch
- ISO / IEC 11801 & EN 50173
- Gigabit Ethernet type CM (UL), C (UL)

Ordering information

Item No.		Description
VIB 5.331		Ethernet cable for VIBXPERT II, 2 m (6' 6.7"), RJ45 to MiniSnap

Note: This cable must not be used with the intrinsically safe VIBXPERT EX.

TECHNICAL INFORMATION

Examples

VIBXPERT II communicating with PC via a network

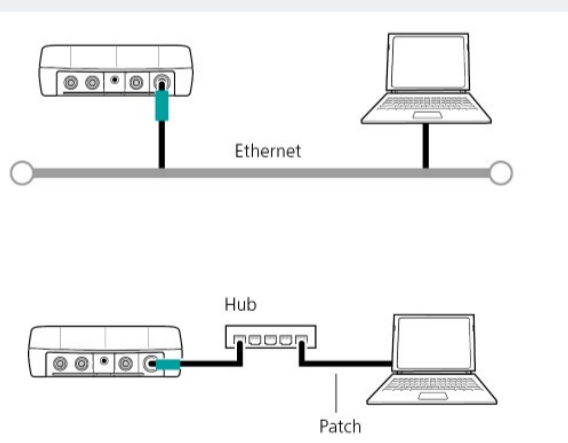

Connect the Ethernet cable to the communication socket (green). A commercially available patch cable is connected to a network interface card. Both cables are then connected to either a network socket or to a hub.

VIBXPERT II communicating with a PC directly via a patch cable

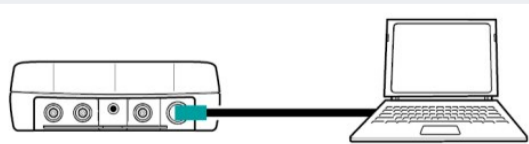

Connect the Ethernet cable to the communication socket (green) and to the network interface card.

Cable adapter for VIBXPERT II

The sensor cable and adapter are used to connect vibration sensors with a voltage output (IEPE) to handheld measurement devices.

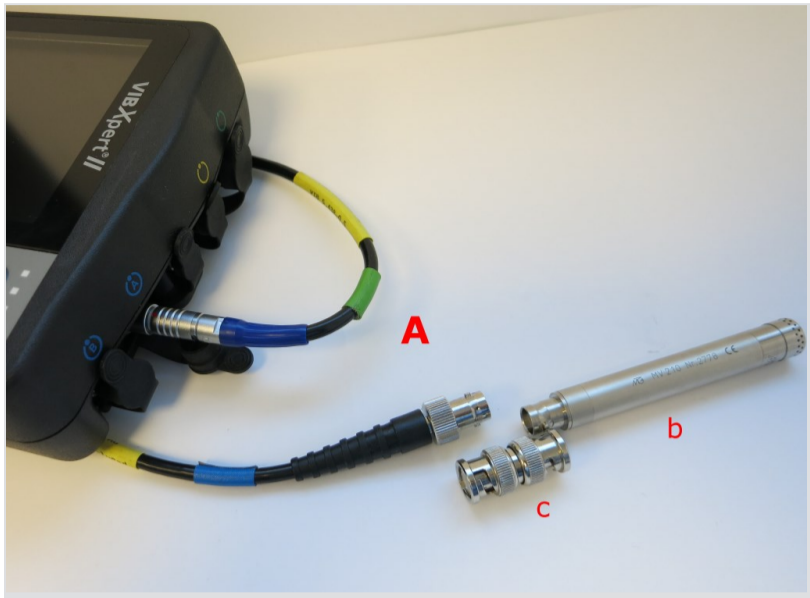

Microphone(b) connected to VIBXPERT II using a BNC coupler (c) and sensor cable VIB 5.438-0,5 (A)

Suited for following portable devices:

- VIBXPERT II
- VIBSCANNER
- VIBGUARD portable

Suited for following types of sensors:

- Accelerometers (IEPE) with BNC cable connection
- Accelerometer 100 mV/g" (IEPE) VIB 6.172
- Triaxial accelerometer VIB 6.655

Ordering information

Item No.		Description
VIB 5.438-0,5		Sensor cable for accelerometer (IEPE), straight, 0.5 m, BNC connector to MiniSnap
VIB 5.422		Sensor cable for accelerometer (IEPE), spiral, 1.8 m, MIL connector to MiniSnap
VIB 5.345-6		Extension for sensor cable with MIL connector, 6 m, MIL plug to MIL socket
VIB 5.449-ICP		Adapter for connecting VIB 6.172 to portable measuring devices
VIB 5.336		Sensor cable for triaxial accelerometer VIB 6.655

TECHNICAL INFORMATION

Accessories

Item No.	Description
Miscellaneous	"Extension cable for analog measuring channel, portable devices", p. 30

Technical data - VIB 5.336

Parameter	VIB 5.336
DESIGN	
Conduct layout	4-pin, AWG25, spiral CTC cable from adapter to sensor
Cable sheath	PU

Parameter	VIB 5.336
Diameter	5.3 mm
Cable length	approx. 0.4 m (15 3/4") device side / approx. 2.6 m (8' 6 23/64") sensor side
ENVIRONMENT	
Temperature range	Operation: -10 °C to 60 °C (14 °F to 140 °F) Storage: -20 °C to 80 °C (-4 °F to 176 °F)
Relative humidity	< 95 %
Environmental protection	IP65
Weight	approx. 310 g

Compatibility overview: Sensor cable – Measurement device

The following overview shows the type of sensor cable that may be connected to the corresponding device. For cables marked with (*), additional cables and/or adapters are required in the measurement chain.

Sensor cable / Adapter	VIBXPERT II	VIBSCANNER	VIBGUARD portable
VIB 5.438-0,5*	✓	✓	✗
VIB 5.422	✓	✓	✗
VIB 5.345-6	✓	✓	✗
VIB 5.449-ICP*	✓	✓	✓
VIB 5.336	✓	✗	✗

Connection cable for field multiplexer on VIBXPert II

Using these cable components, VIBXPert II can be connected to and operated on a string line of up to 6 VIBRONET field multiplexers for automated data acquisition.

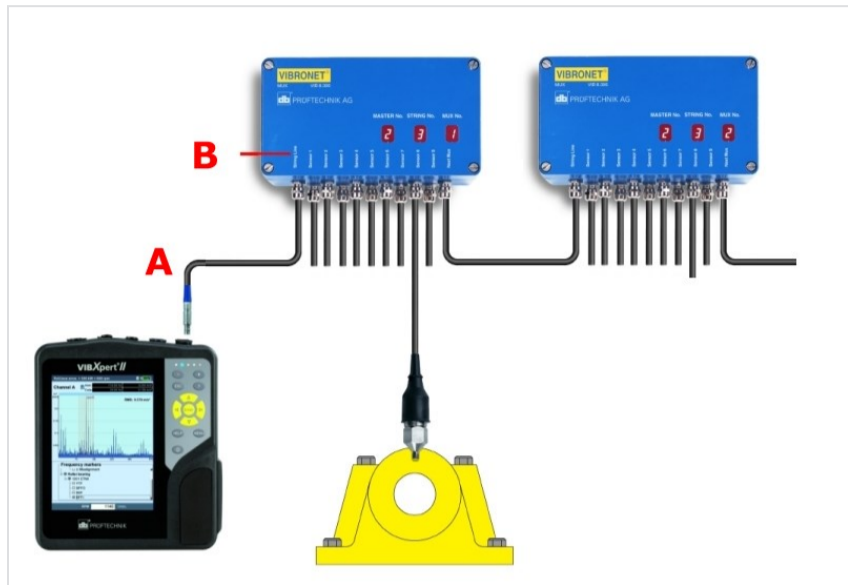



Connect VIBXPert II with field multiplexer via connection cable (A) and cable adapter (B).

Features

- Up to 54 measuring locations possible
- Safe and fast data acquisition on site
- No power supply required
- For vibration sensors with current output (CLD)

Ordering information

Item No.		Description
VIB 5.346		Connection cable, VIBXPert II to VIBRONET field multiplexer, 1.5 meters, BNC to MiniSnap
VIB 5.346-MUX		Cable adapter for connection cable VIB 5.346 (installed in field multiplexer), 25 cm

Note: These cables must not be operated with VIBXPert EX.

Accessories

Item No.	Description
VIB 5.444-5	"Extension cable for analog measuring channel, portable devices", p. 30

TECHNICAL INFORMATION

Installation example

Cable adapter (B) installed on main board in field multiplexer.

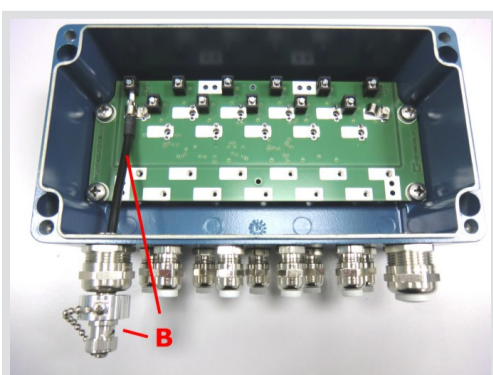

Serial PC cables - RS232

The cables are used for data transmission via the serial interface (RS232) of the measuring instrument. The adapter cable "USB-Serial" is intended for VIBSCANNER but is necessary if the PC possesses only USB ports.





Suited for following handheld devices:

- VIBSCANNER
- VIBXPERT II

Serial PC cable connected to VIBXPERT II

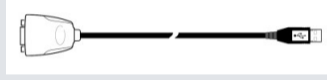
Ordering information

Item No.		Description
VIB 5.430-2		Serial PC cable, 2 m, D-Sub9 (f) to MiniSnap
VIB 5.448		VIBSCANNER adapter cable, "USB - Serial", 0.2 m, D-Sub9 (f) to USB
VIB 5.430-USB		VIBSCANNER EX adapter cable "USB - Serial", MiniSnap to USB

Note: The serial PC cable must not be used with the intrinsically safe VIBXPERT EX.

TECHNICAL INFORMATION

Examples

VIBXPERT II communicating with a PC via the serial port

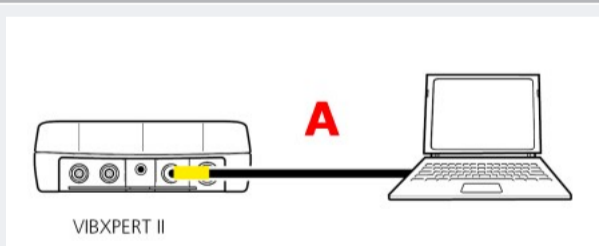

Connect the device digital socket (yellow) to the PC serial port using the cable (A).

**VIBSCANNER communicating with a PC via the serial interface
and the "USB - Serial" adapter cable**

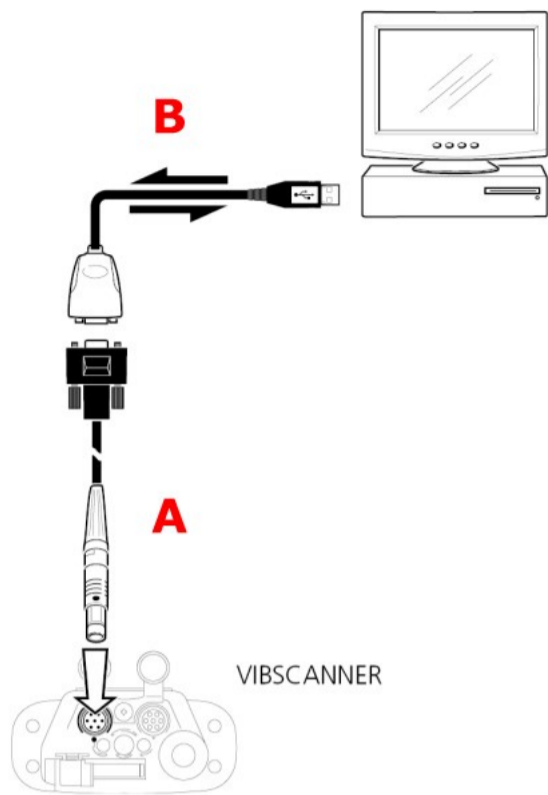

Connect the PC cable (A) to the digital socket (yellow). Connect the cable adapter "USB - Serial" (B) to the USB port on the PC. Connect cables A and B together.

Cables for signal output – handheld devices

These cables are used to connect headphones or external analytical instrument to a handheld data collector.

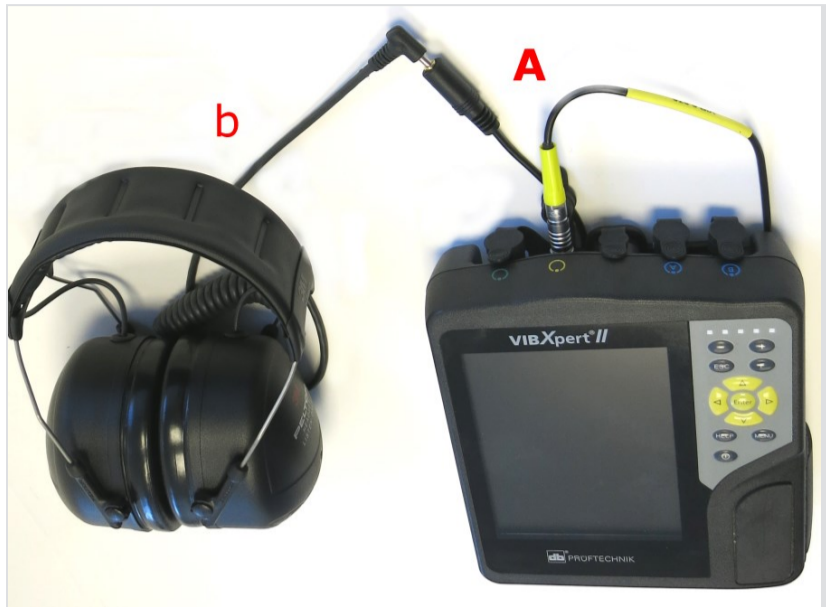

Mono headphones (b) attached to VIBXPERT II via the sensor cable VIB 6.675 (A)



Compatible with the following handheld devices:

- VIBXPERT II, VIBXPERT EX
- VIBSCANNER, VIBSCANNER EX

Suitable for following instruments and devices:

- Signal analyzers such as oscilloscopes
- Mono headphones VIB 6.671

Ordering information

Item No.		Description
VIB 5.431		Connection cable to an external analytical instruments — spiral, 1.8 m (5' 10 9/10"), BNC socket to MiniSnap
VIB 6.675		Connection cable für mono headphones VIB 6.671 — straight, 1 m (3' 3 4/10"), mono jack to MiniSnap

TECHNICAL INFORMATION

Compatibility overview: Connection cable – Handheld device

The following overview shows which is compatible to which handheld device.

Connection cable	VIBXPERT II	VIBXPERT EX	VIBSCANNER	VIBSCANNER EX
VIB 5.431	✓	✓	✓	✓
VIB 6.675	✓	✗	✓	✗

Application

VIBXPERT II: Signal analysis using an oscilloscope

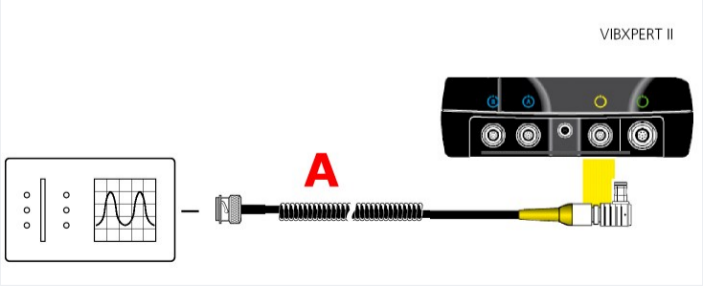

A: Connection cable VIB 5.431

Pre-assembled sensor cables for measuring low signal voltage/low signal current, portable measuring devices

These sensor cables are used for measuring small signal voltages or level signals provided by other measuring instruments.

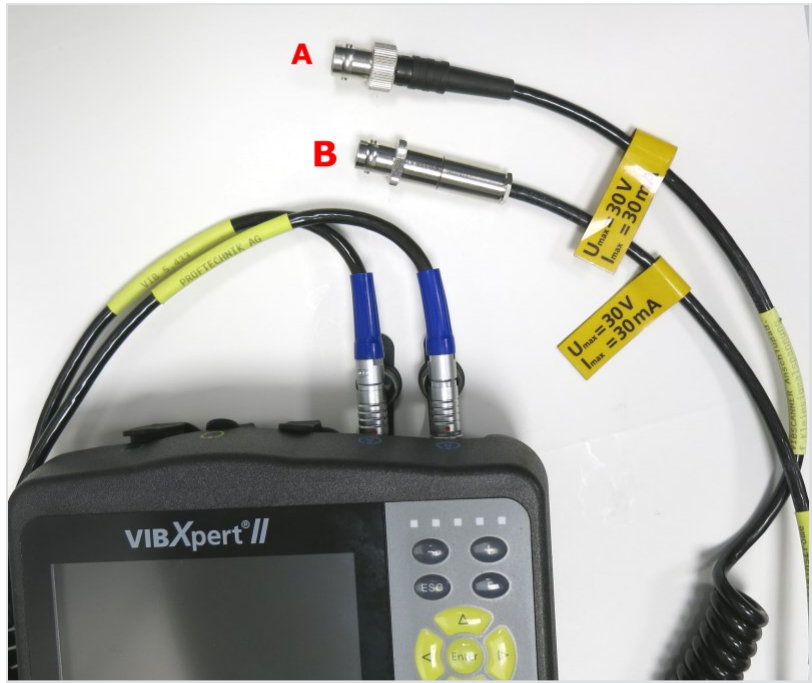

Compatible with the following measuring devices:

- VIBXPERT II / VIBSCANNER
- VIBXPERT EX / VIBSCANNER EX

Signal types:

- Voltage, AC: 0-30 V
- Voltage, DC: 0-30 V
- Current, DC: 0-30 mA

Sensor cables for measuring small signal voltage (A) and small signal current (B) connected to VIBXPERT II.

Ordering information

Item No.		Description
VIB 5.433		Sensor cable for measuring small signal voltage with VIBSCANNER / VIBXPERT II, spiraled, 1.8 meters, BNC socket to MiniSnap
VIB 5.433 X		Sensor cable for measuring small signal voltage with VIBSCANNER EX / VIBXPERT EX, spiraled, 1.8 meters, BNC socket to MiniSnap
VIB 5.434		Sensor cable for measuring small signal current with VIBSCANNER / VIBXPERT II, spiraled, 1.8 meters, BNC socket to MiniSnap

Notes: An additional cable with at least one BNC plug is required to connect the sensor cable to the measuring instrument. These sensor cables may only be operated **outside** of the EX zone!

All circuits in the VIBXPERT II are DC coupled. When more than one circuit is connected, faults may occur in the case of potential differences.

TECHNICAL INFORMATION

Accessories

Item No.	Description
Misc.	"Extension cable for analog measuring channel, portable devices", p. 30

Technical data, VIB 5.433 X

Parameter	VIB 5.433 X
Temperature range	0°C ... + 40 °C (32...104 °F)
Maximum measurement error	-2.0% / +2.7%
f _{max} AC measurement	5 kHz

Note: VIBXPERT EX resp. VIBSCANNER EX may only be operated with this cable for voltage measurements. The cable protects the analog interfaces on the measuring device from overvoltages. The cable may only be connected outside of the EX zone, to a circuit, whose maximum voltage does not exceed 265 V_{eff}, even in the case of an error.

Application examples

VIBXPERT II: Shaft vibration measured as a voltage signal on a machine protection system (e.g. Bently Nevada 3300)

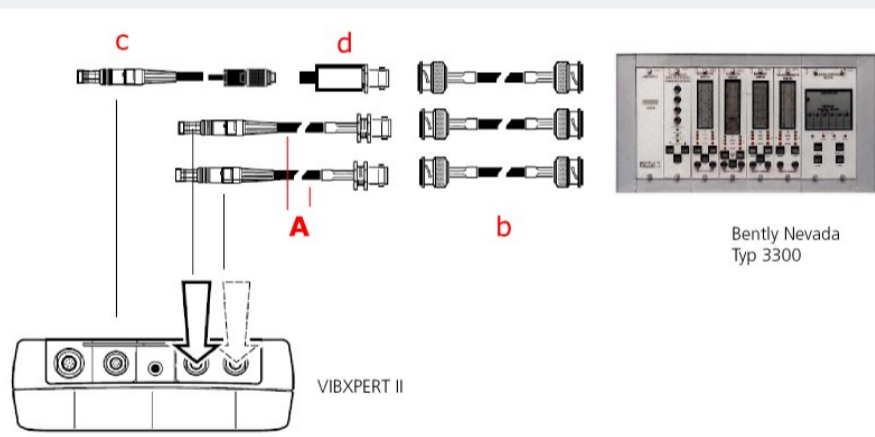

- A: Sensor cable for measurement of signal-low voltage VIB 5.433 (2 pieces)
- b: Coaxial cable with BNC connector, 3 pieces
- c: Sensor cable for trigger / RPM sensor VIB 5.432-2,9
- d: Keyphasor adapter VIB 5.332 X

VIBXPERT II: Pressure as current level (4-20 mA), resp. flow rate as current or voltage level (4-20 mA / 0-10 V)

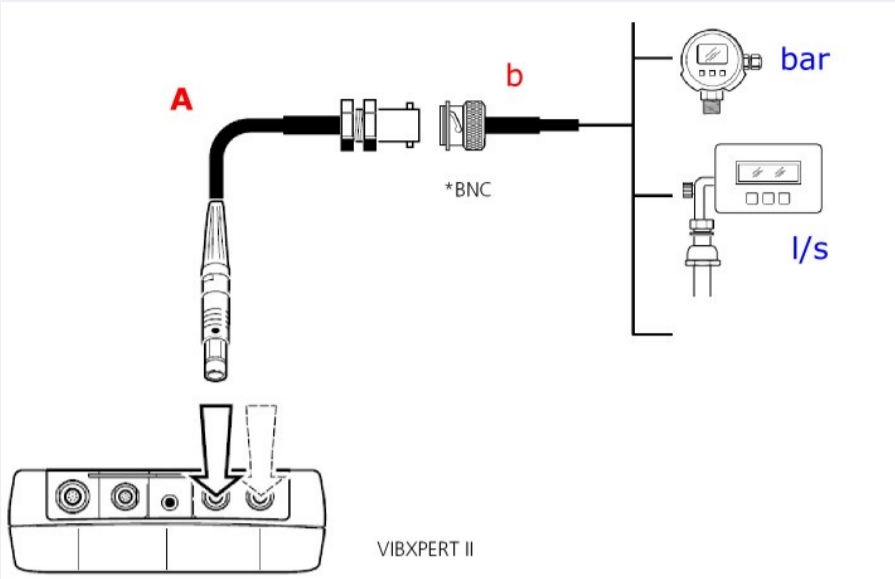

A: Sensor cable for measuring small signal voltage, VIB 5.433, or small signal current, VIB 5.434
For VIBXPERT EX: Use sensor cable VIB 5.433 X.
b: Coax cable with BNC plug, signal cable from sensor

Mono headphones

The mono headphones can be used to listen to the machines and, in particular, roller bearings for the characteristic noises that indicate damage. The buffered sensor signal is picked at the data collectors analog output. The appropriate adapter cable is available as an accessory.



Features

- Frequency range: 125 Hz to 8000 Hz
- Suitable for VIBXPERT II, VIBSCANNER

Mono headphones for VIBXPERT II and VIBSCANNER.

Ordering information

Item No.	Description
VIB 6.671	Mono headphones

Accessory

Item No.	Description / Group
VIB 6.675	"Cables for signal output – handheld devices", p. 65

TECHNICAL INFORMATION

Technical data

Parameter	VIB 6.671
ELECTRICAL	
Impedance	230 Ohm
Frequency range	125 - 8000 Hz
Sound pressure level at 198 mV	82 dB (A)
Resonance frequency	17 kHz; > 20 dB damped
GENERAL	
Connection	Adapter cable VIB 6.675 for VIBSCANNER / VIBXPERT II (MiniSnap)
Weight	381 g

LED stroboscope

This stroboscope is used in combination with VIBXPRT II to analyze rotary motion as well as measuring phase shift, RPM and velocity. The stroboscope uses high-intensity LEDs. The flash rate may be either controlled internally, or set via an external trigger signal.



LED stroboscope for analysis of rotary motion

Scope of supply

- LED stroboscope
- Trigger cable 1.5 m, including BNC connector
- Hard shell box
- Set of batteries (2x AA / LR6)
- Operating manual

Ordering information

Item No.	Description
VIB 6.672	LED stroboscope

Accessories

Item No.	Description
VIB 5.333	Cable adapter for LED stroboscope (VIBXPRT II), see: "Pre-assembled sensor cable and adapter for trigger / RPM sensor (portable devices)", p. 35

TECHNICAL INFORMATION

Technical data

Parameter	VIB 6.672
MEASUREMENT	
Light source	3 CREE LEDs
Light intensity	3800 Lux max. (@ 50 Hz / 20 cm)
Frequency range	1 - 2000 Hz / 60 - 99999 min-1
Control of the flash rate	Internal: Membrane keyboard; External: external trigger signal
Phase shift	0° to 360°
Operating temperature	0 °C to 40 °C (32 °F to 104 °F)

Parameter	VIB 6.672
Operating time	< 15 h
GENERAL	
Dimensions	140 x 63 x 38 mm (5 11/16" x 2 1/2" x 1 1/2")
Weight	175 g (6.2 oz)
Storage temperature	-20 °C to 70 °C (-20 °F to 70 °F)
Relative humidity	< 80% at 30 °C (86 °F)
Environmental protection	IP 40

Application

VIBXPRT II: Measuring RPM using the LED stroboscope VIB 6.672

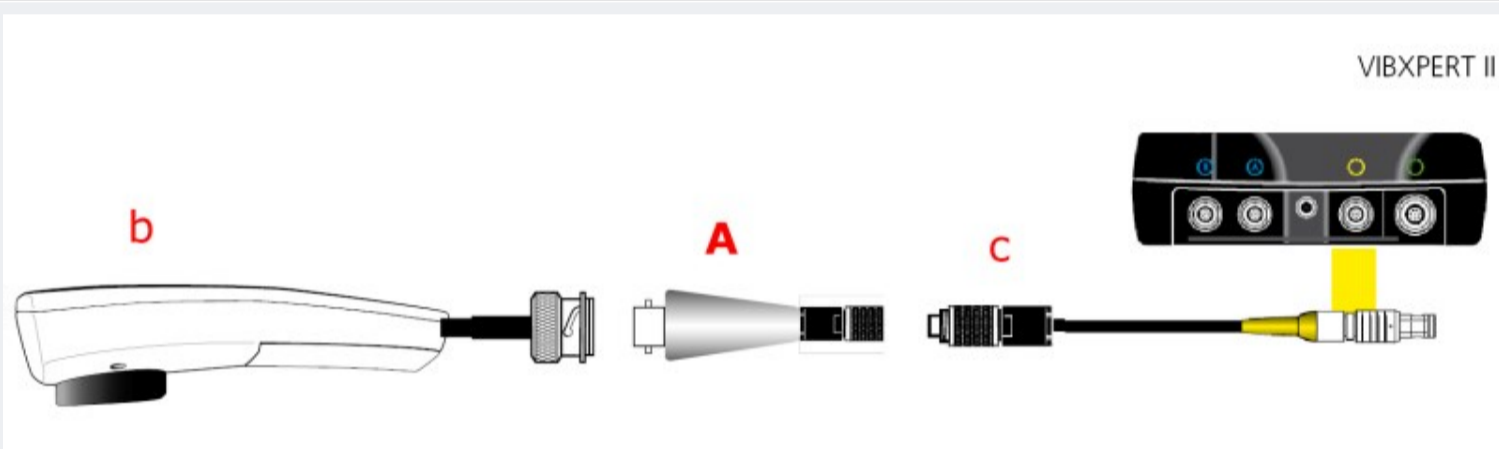

A: Cable adapter for LED stroboscope, VIB 5.333

b: LED stroboscope, VIB 6.672

c: Sensor cable, VIB 5.432-2,9

Current clamp (400 A AC / 600 A DC)

The current clamp is used in combination with VIBXPERT II to measure both AC and DC current. The current clamp can also measure power and true-rms (for nonsinusoidal waveforms). The current clamp works on the principle of the Hall effect. A push button operates the automatic DC zeroing. The cable adapter for signal low voltage is required to connect the current clamp to VIBXPERT II.



Scope of supply

- Current clamp
- 9 V battery
- Operating manual

Ordering information

Item No.	Description
VIB 6.673	Current clamp 600 A DC

Accessories

Item No.	Description
VIB 5.433	"Pre-assembled sensor cables for measuring low signal voltage/low signal current, portable measuring devices", p. 66

TECHNICAL INFORMATION

Technical data

Parameter	VIB 6.673	
ELECTRICAL		
Calibre	60 A	600 A
Current range	0.2 A to 40 A AC 0.4 A to 60 A DC	0.5 A to 400 A AC 0.5 A to 600 A DC
Output signal	10 mV/A	1 mV/A
Accuracy*	0.5 A to 40 A: 1.5% ±5mV 40 A to 60 A DC: 1.5%	0.5 A to 100 A: 1.5% ±1mV 100 A to 400 A DC: 2% 400 A to 600 A DC: 2.5%
Phase shift (45 - 65 Hz)*	10 A to 20 A : < 3° 20 A to 40 A : < 2°	10 A to 100 A : < 2° 100 A to 400 A : < 1.5°
Noise	DC ... 1 kHz : < 8mV DC ... 5 kHz : < 12mV 0.1 Hz ..5 kHz : < 2mV	DC ... 1 kHz : < 1mV DC ... 5 kHz : < 1.5mV 0.1 Hz...5 kHz : < 0.5mV

Parameter	VIB 6.673	
Rise/Fall time	< 100 µs from 10 to 90% of the voltage value	< 70 µs from 10 to 90% of the voltage value
Overload	2000 A DC / 1000 A AC bei 1kHz max.	
Bandwidth	DC ... 10 kHz at -3dB	
Load impedance	> 1 MOhm and < 100 pF	
Operating voltage	600 V RMS	
Power supply	9 V alkaline battery (IEC 6LR61)	
Low battery signal	Green LED when battery voltage > 6.5 V	
Battery life	Approximately 50 hours	
Overload indicator	Red LED	
Automatic turn off	After 10 minutes of inactivity	
MECHANICAL		
Operating temperature	-10 °C to 55 °C (14 °F to 131 °F)	
DC zero adjustment	Automatically operated by a push button (± 10 A)	
Maximum jaw insertion capacity	1 cable Ø 30 mm (1 3/16") or 2 cables Ø 24 mm (15/16")	
Environmental protection	IP 30	
Dimensions	224 x 97 x 44 mm (8 13/16" x 3 13/16" x 1 47/64")	
Weight	440 g (16 oz)	
Connection	Coaxial cable, 2 m; with BNC connector	

* Conditions of reference: 18° at 28°C, 20 to 75% relative humidity, 48 to 65 Hz, external magnetic field < 40 A/m, no DC component, no current-carrying conductor nearby, centred test sample, charge ≥ 1 MOhm and ≤ 100 pF, reset to zero before measurement (only DC) DC to 65 Hz, batteries 9 V ±0.1 V

Connection diagram

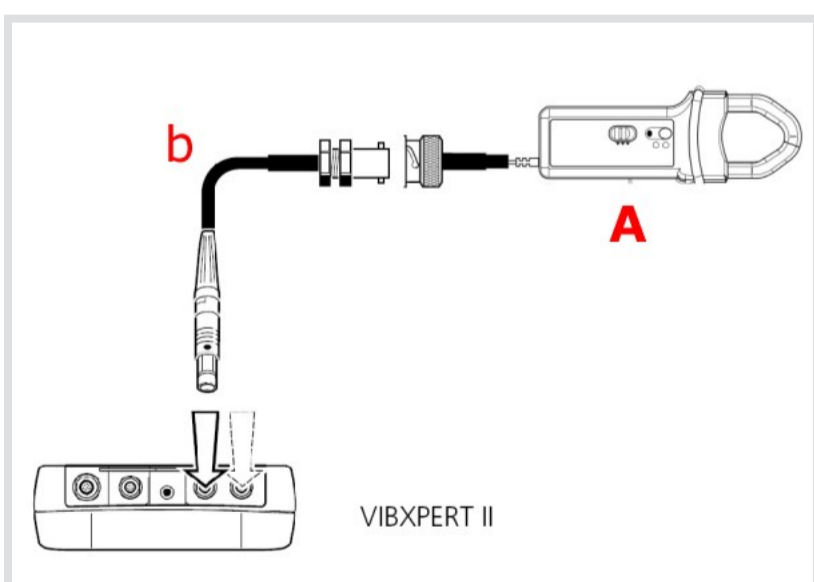

Current clamp (A) connected to VIBXPART II using the cable adapter for signal low voltage (b)

Tools for cable installation

These tools are used to assemble coax cables at the point of installation.



Crimp tool and cutting tool for coax cable.

Features

- Crimp tool:
 - for coax cable RG 58/59/6/174
 - Crimping dies can be replaced
- Cutting tool, composed of
 - Stripping tool
 - Blade cassette

Ordering information

Item No.	Name
VIB 81026	Crimping tool for coax cable
VIB 81052	Cutting tool for coax cable

Note: The replaceable blade cassette has a specified stripping length. In combination with the stripping tool, it is suitable for coax cables and round (shielded) data lines of between 2.5 and 8 mm in diameter. The blade cassette enables 1, 2 and 3-stage stripping. Stripping length: 7.5/3.5 mm.

Tools for installation of accelerometers

This drilling tool is used when mounting sensors with screw threads. The special countersink is intended to prepare a measurement location for the vibration sensor installed in the VIBSCANNER.

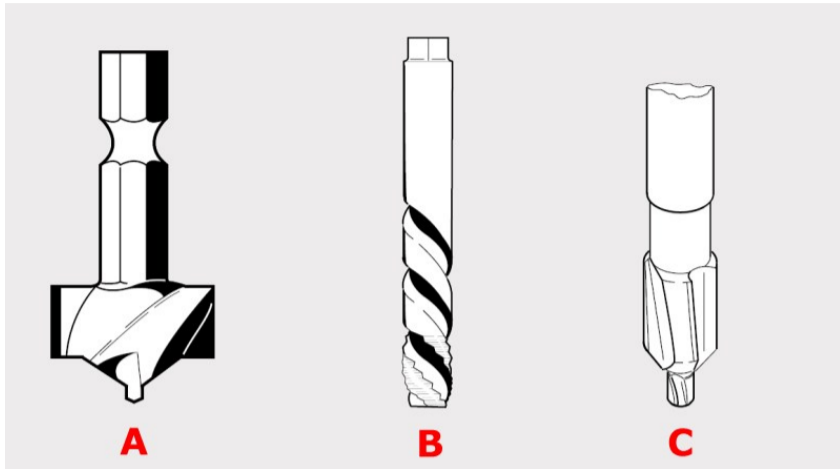

Overview

- Thread cutter M8 and UNC 5/16
- 90° countersink for sensors with a cone base
- Special countersink for VIBSCANNER sensor

VIBSCANNER special countersink (A), thread cutter (B), 90° countersink (C).

Ordering information

Item No.	Name
VIB 8.610	Special countersink, VIBSCANNER
VIB 8.693	Thread cutter M8
VIB 8.694	90° countersink
VIB 8.696	Thread cutter UNC 5/16

TECHNICAL INFORMATION

Application example

Preparation of a measurement location for the VIBSCANNER vibration sensor with the special countersink.

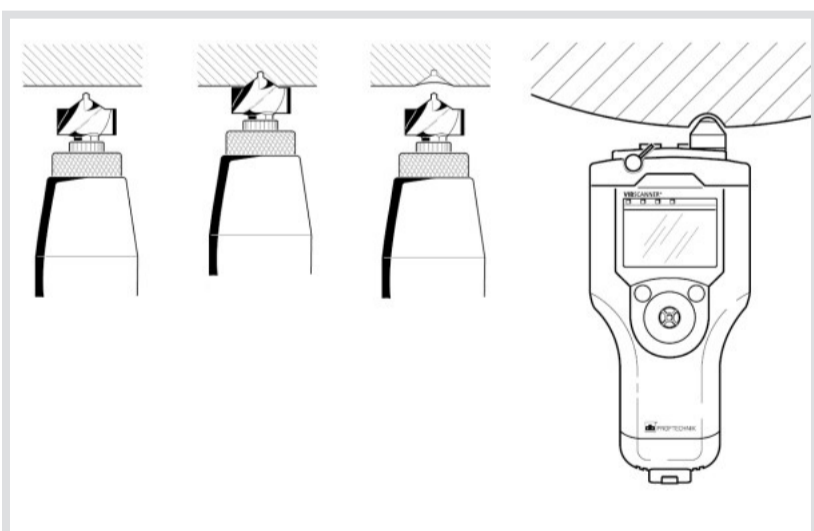

Productive Maintenance Technology



PRÜFTECHNIK
85737 Ismaning, Germany
www.pruftechnik.com